

Digital Image Processing

Lecture # 3 **Image Enhancement**

Image Enhancement

Image Enhancement



Image Enhancement

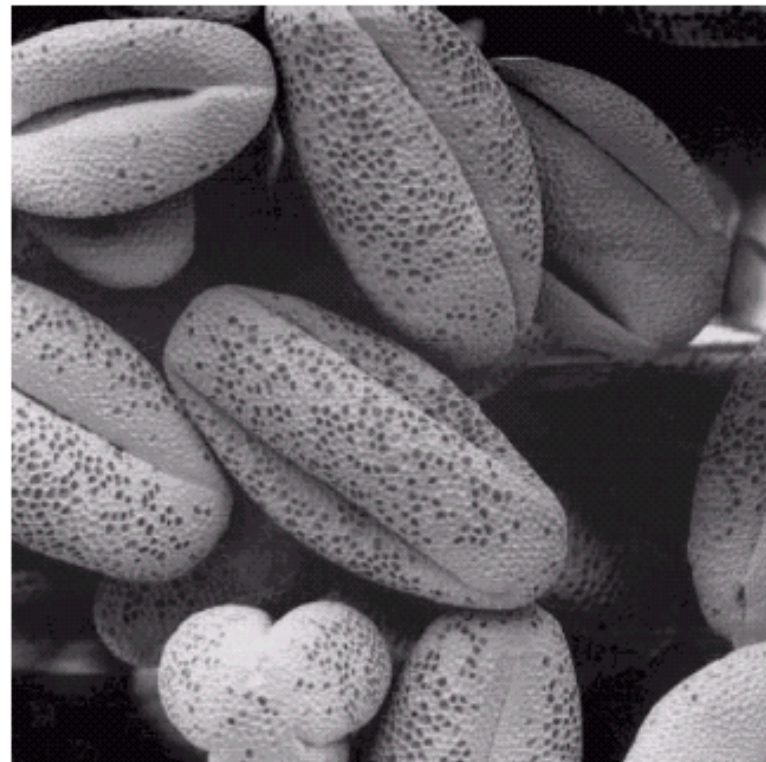
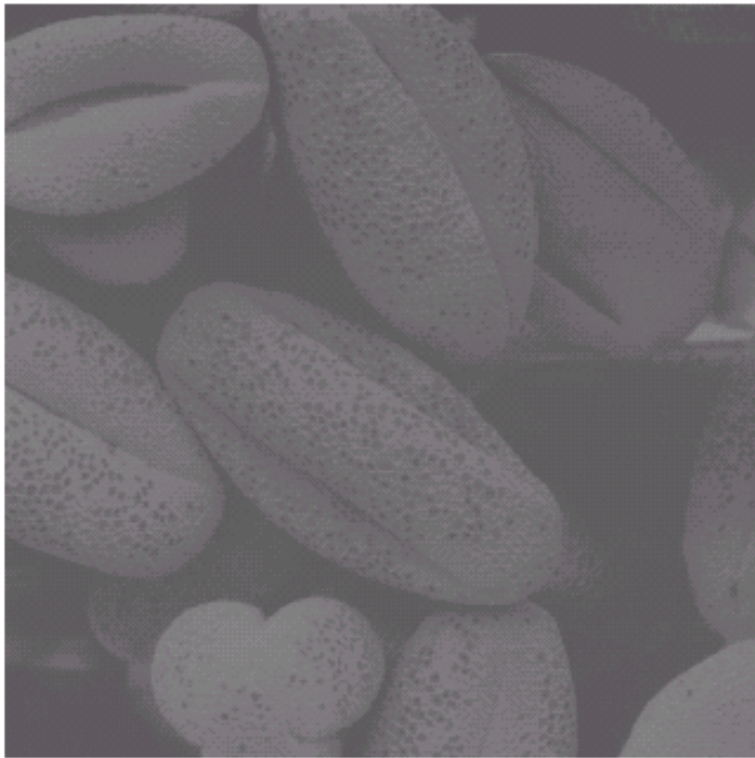

Image Enhancement

Process an image so that the result is more suitable than the original image for a **specific application**

- ◆ Image Enhancement Methods
 - **Spatial Domain**: Direct manipulation of pixels in an image
 - **Frequency Domain**: Process the image by modifying the Fourier transform of an image

This Chapter – Spatial Domain



Types of image enhancement operations

- ◆ Point/Pixel operations

Output value at specific coordinates (x,y) is dependent only on the input value at (x,y)

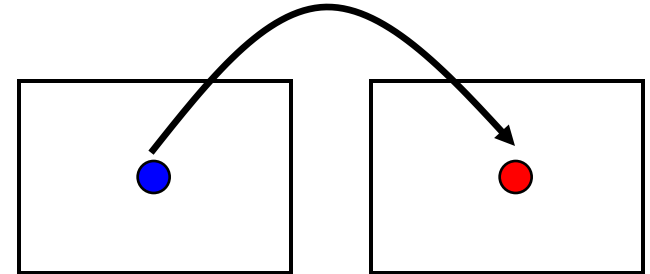

- ◆ Local operations

The output value at (x,y) is dependent on the input values in the neighborhood of (x,y)

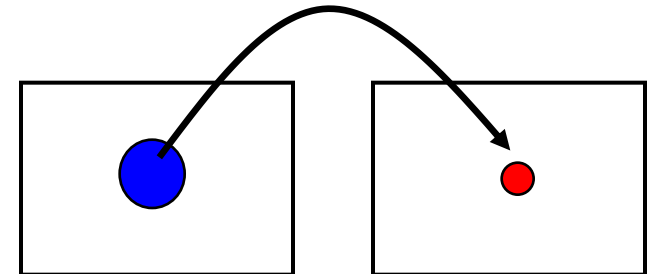

- ◆ Global operations

The output value at (x,y) is dependent on all the values in the input image

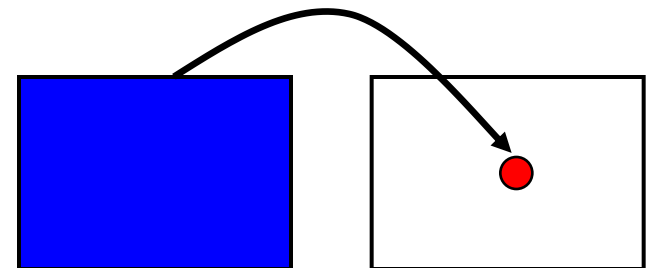

Basic Concepts

- ◆ Most spatial domain enhancement operations can be generalized as:

$$g(x, y) = T[f(x, y)]$$

$f(x, y)$ = the input image

$g(x, y)$ = the processed/output image

T = some operator defined over some neighbourhood of (x, y)

Basic Concepts

A square or rectangular sub-image area centered at (x,y)

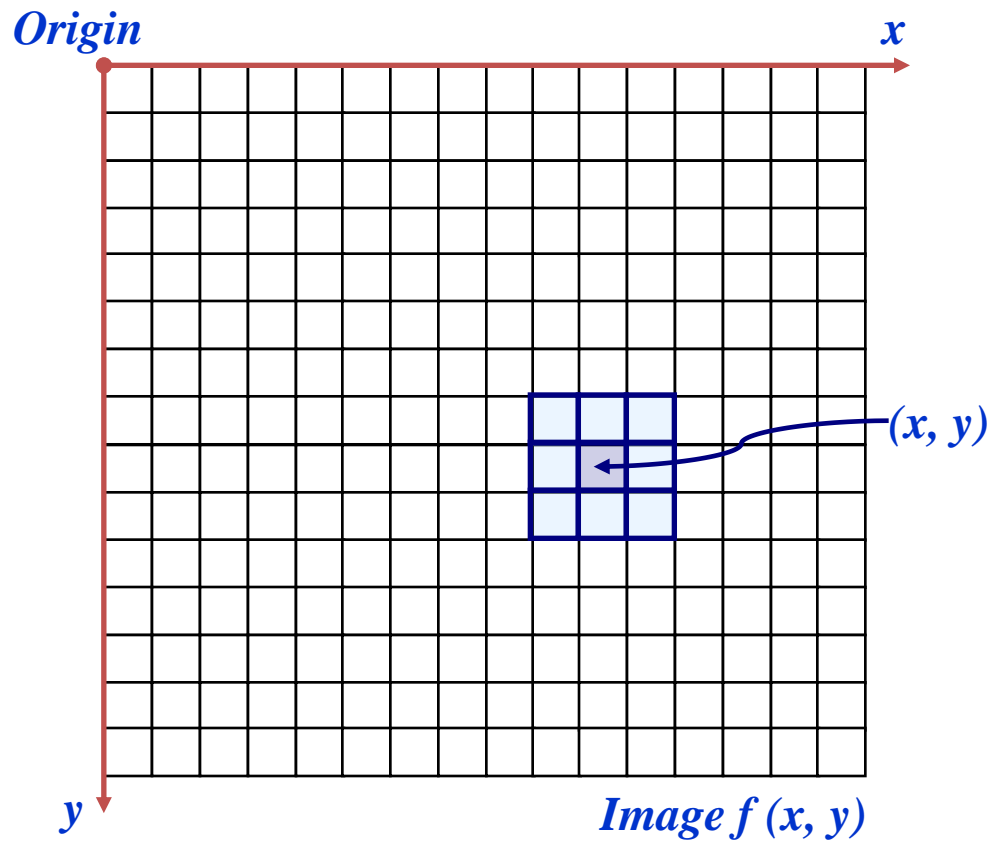

Point Processing

- ◆ In a digital image, point = pixel
- ◆ Point processing transforms a pixel's value as function of its value alone;
- ◆ It does not depend on the values of the pixel's neighbors.

Point Processing

- ◆ Neighborhood of size 1x1:
- ◆ g depends only on f at (x,y)
- ◆ T : Gray-level/intensity transformation/ mapping function

$$s = T(r)$$

- $r =$ gray level of f at (x,y)
- $s =$ gray level of g at (x,y)

Point Processing using Look-up Tables

A look-up table (LUT) implements a functional mapping.

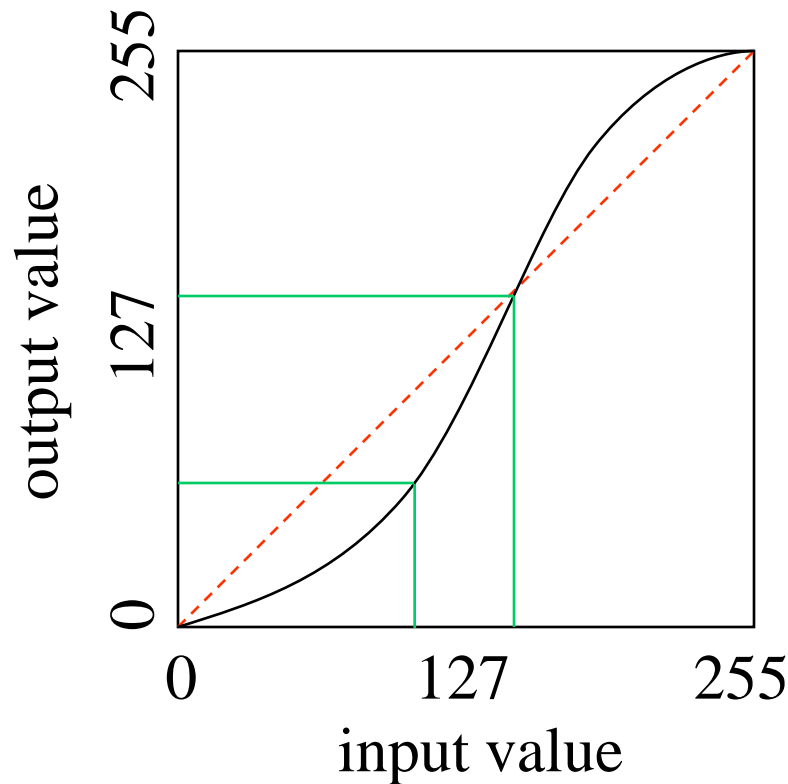

E.g.:

index	value
...	...
101	64
102	68
103	69
104	70
105	70
106	71
...	...

input output

Point Processing using Look-up Tables

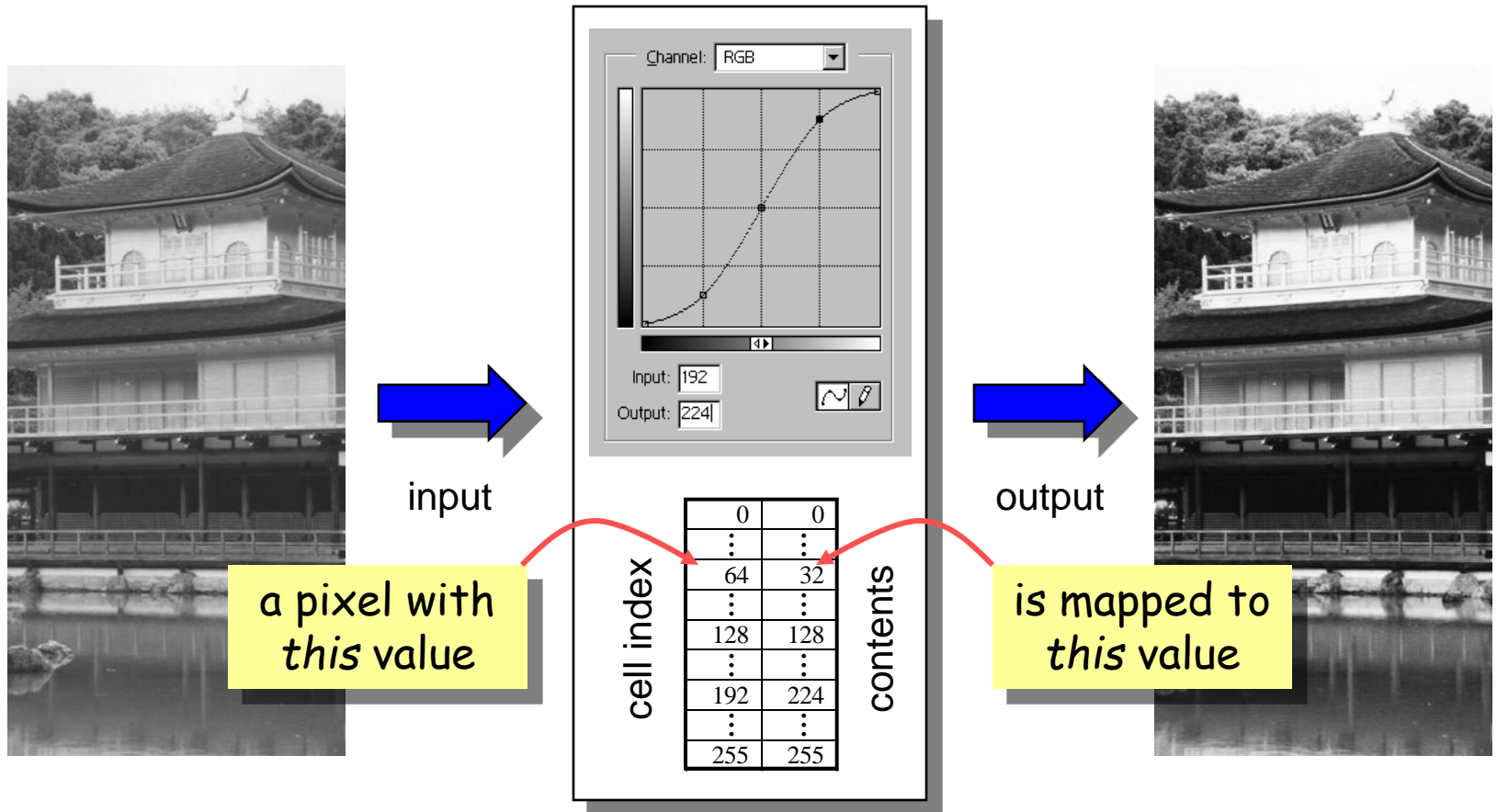

POINT PROCESSING

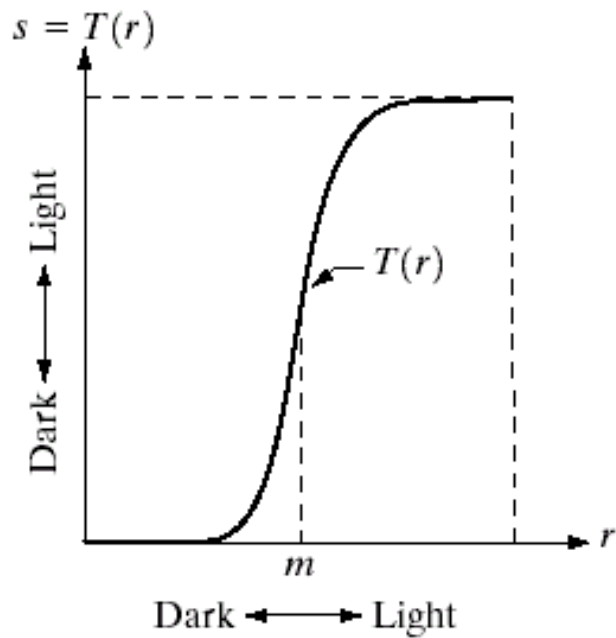

Contrast Stretching

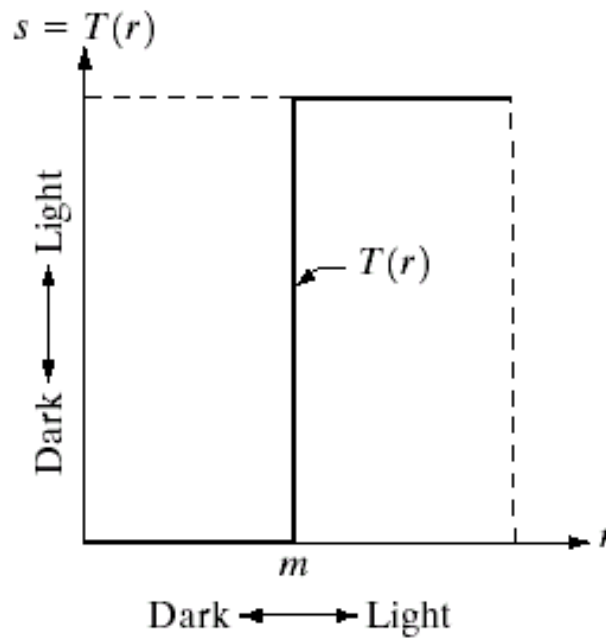

Thresholding

a b

FIGURE 3.2 Gray-level transformation functions for contrast enhancement.

Point Processing Example: Thresholding

$$s = \begin{cases} 1.0 & r > \textit{threshold} \\ 0.0 & r \leq \textit{threshold} \end{cases}$$

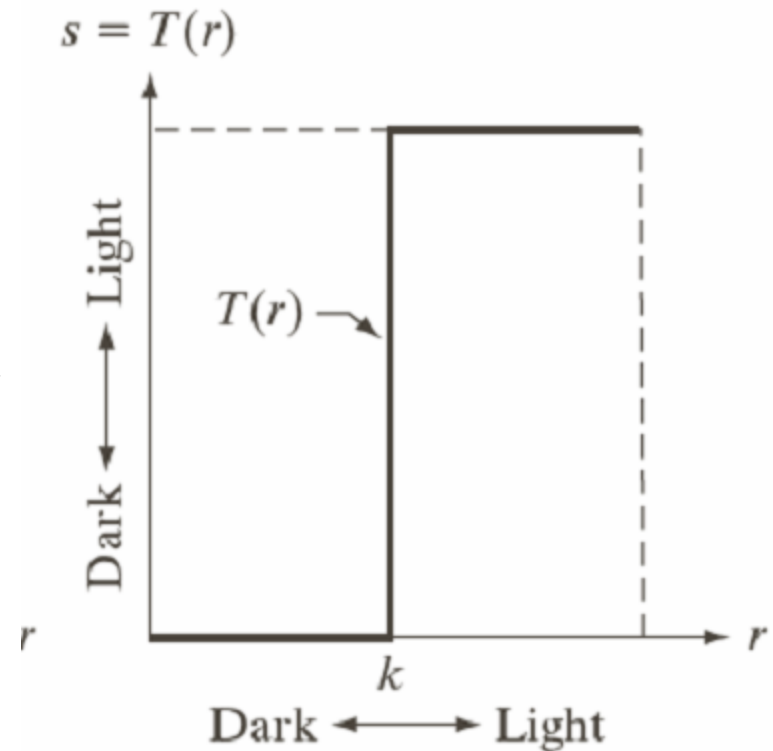

Point Processing Example: Thresholding

- ◆ Segmentation of an object of interest from a background



$$s = \begin{cases} 1.0 & r > \text{threshold} \\ 0.0 & r \leq \text{threshold} \end{cases}$$

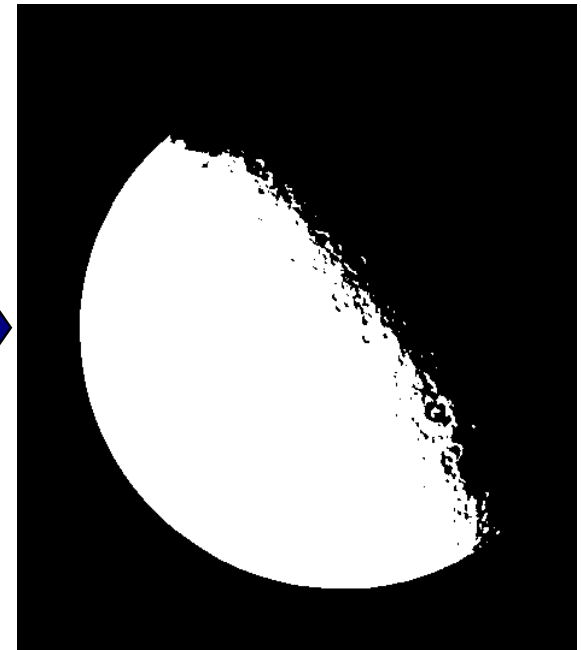

Point Processing Example: Intensity Scaling

$$s = T(r) = a \cdot r$$

Original image

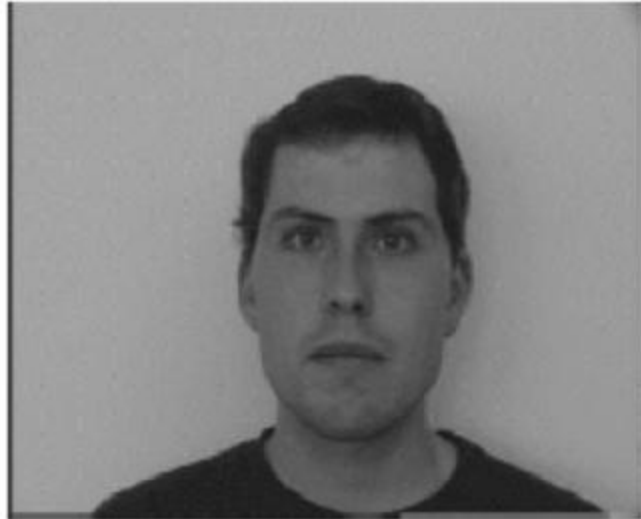

$f(x,y)$

Scaled image



$a \cdot f(x,y)$

Point Processing Transformations

- ◆ There are many different kinds of grey level transformations
- ◆ Three of the most common are shown here

- Linear

- Negative/Identity

- Logarithmic

- Log/Inverse log

- Power law

- n^{th} power/ n^{th} root

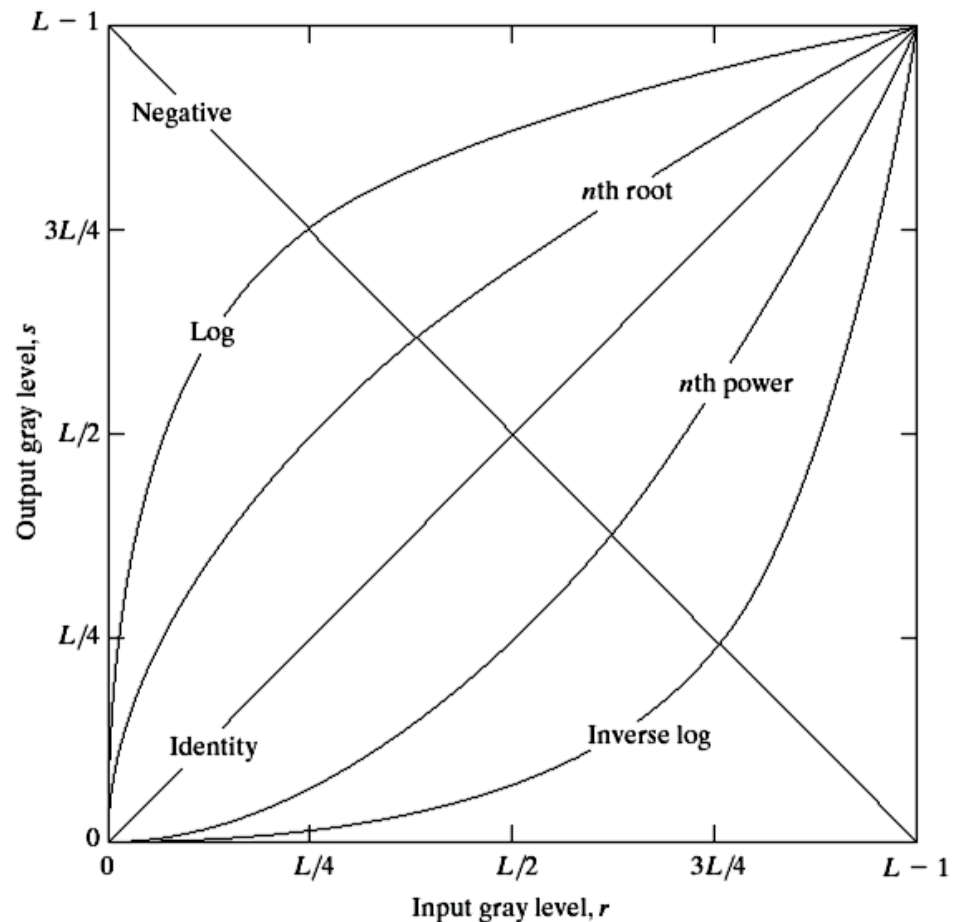

Point Processing Example: Negative Images

- ◆ Reverses the gray level order
- ◆ For L gray levels, the transformation has the form:

$$s = (L - 1) - r$$

- ◆ Negative images are useful for enhancing white or grey detail embedded in dark regions of an image

Point Processing Example: Negative Images



Input image (X-ray image)

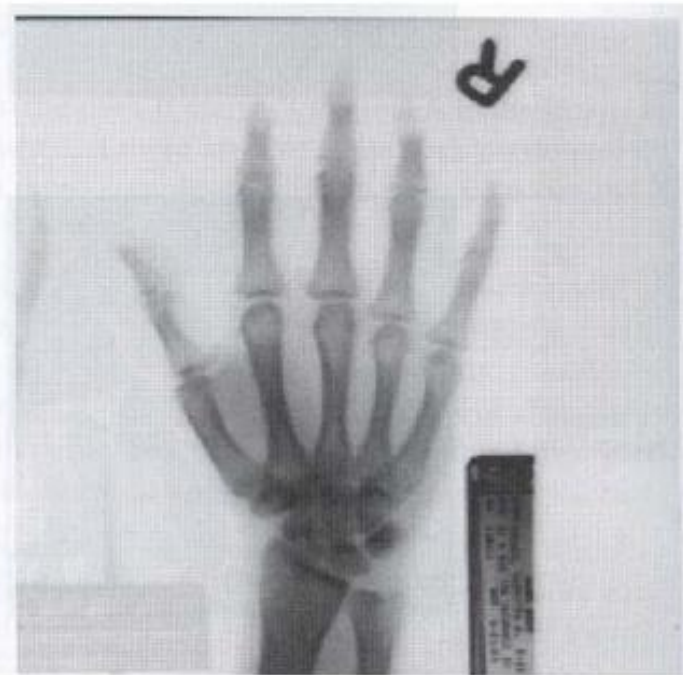

Output image (negative)

Logarithmic Transformations

- ◆ The general form of the log transformation is

$$s = c \times \log(1 + r)$$

- ◆ The log transformation maps a narrow range of low input grey level values into a wider range of output values
- ◆ The inverse log transformation performs the opposite transformation

Logarithmic Transformations

◆ Properties

- For lower amplitudes of input image the range of gray levels is expanded
- For higher amplitudes of input image the range of gray levels is compressed

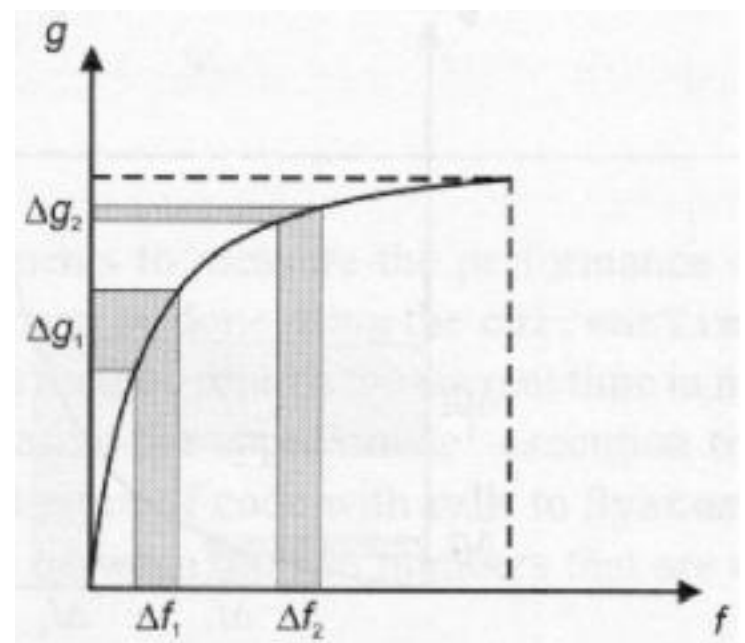

Logarithmic Transformations

◆ Application

- This transformation is suitable for the case when the dynamic range of a processed image far exceeds the capability of the display device (e.g. display of the Fourier spectrum of an image)
- Also called “dynamic-range compression / expansion”

Logarithmic Transformations

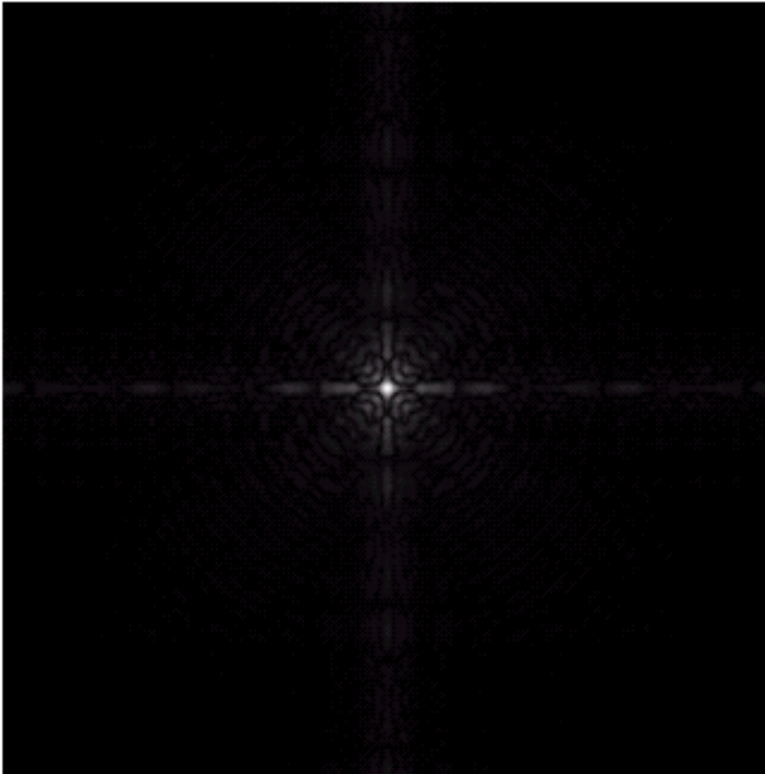

Fourier spectrum: image values ranging from 0 to 1.5×10^6

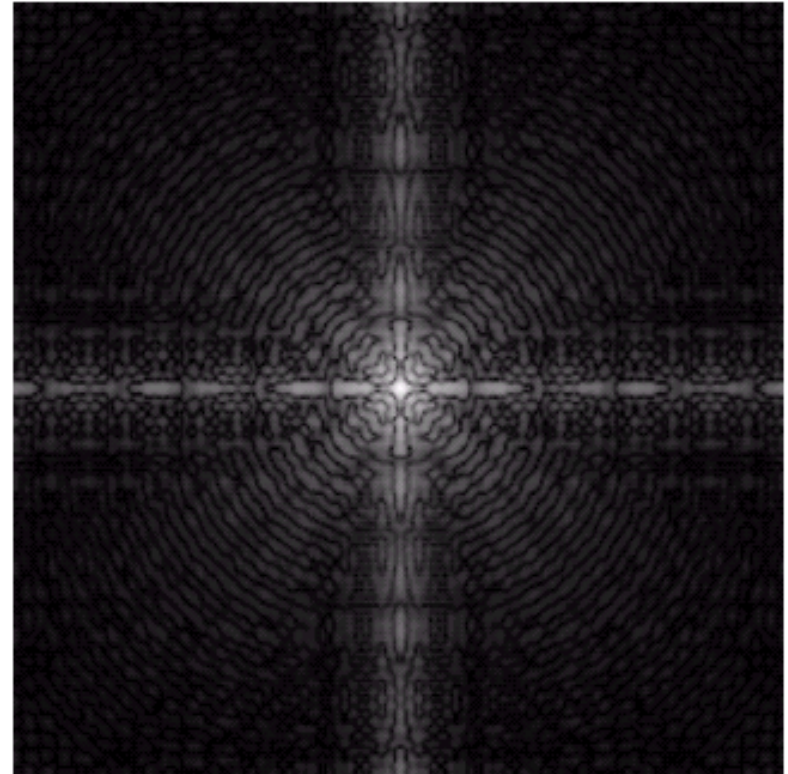

The result of log transformation with $c = 1$

Power Law Transformations

- ◆ Power law transformations have the following form

$$s = c \times r^\gamma$$

- ◆ Map a narrow range of dark input values into a wider range of output values or vice versa
- ◆ Varying γ gives a whole family of curves

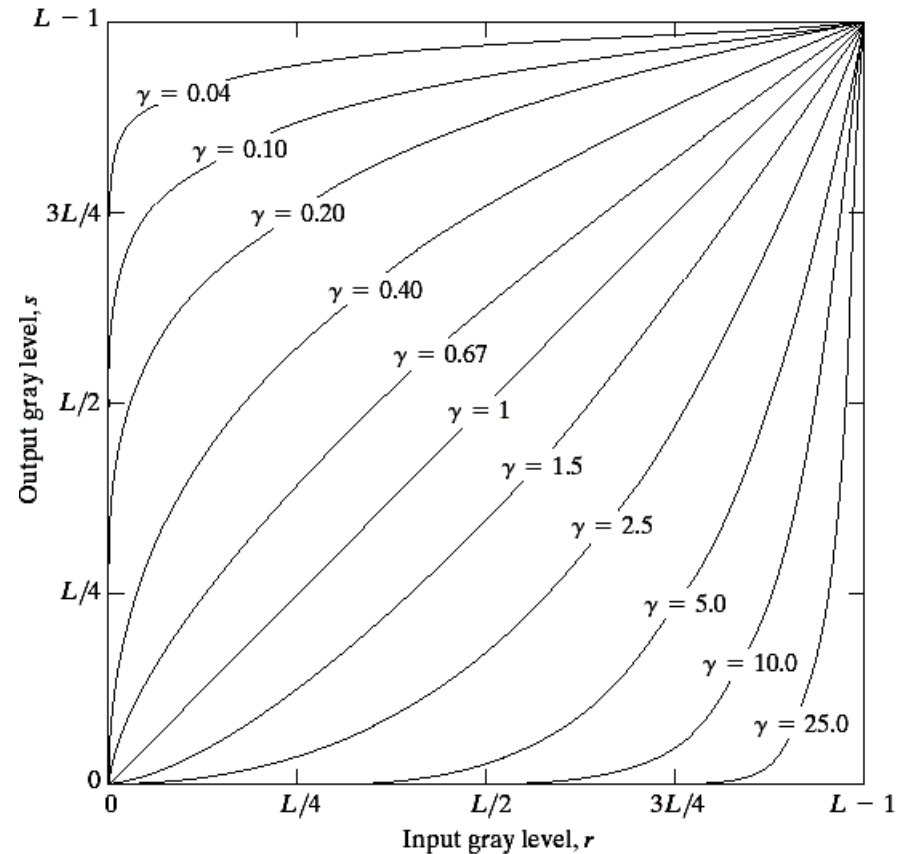

Power Law Transformations

- ◆ For $\gamma < 1$: Expands values of dark pixels, compress values of brighter pixels
- ◆ For $\gamma > 1$: Compresses values of dark pixels, expand values of brighter pixels
- ◆ If $\gamma=1$ & $c=1$: Identity transformation ($s = r$)
- ◆ A variety of devices (image capture, printing, display) respond according to a power law and need to be corrected
- ◆ **Gamma (γ) correction**
The process used to correct the power-law response phenomena

Power Law Transformations: Gamma Correction

a b
c d

FIGURE 3.7

(a) Linear-wedge gray-scale image.
(b) Response of monitor to linear wedge.
(c) Gamma-corrected wedge.
(d) Output of monitor.

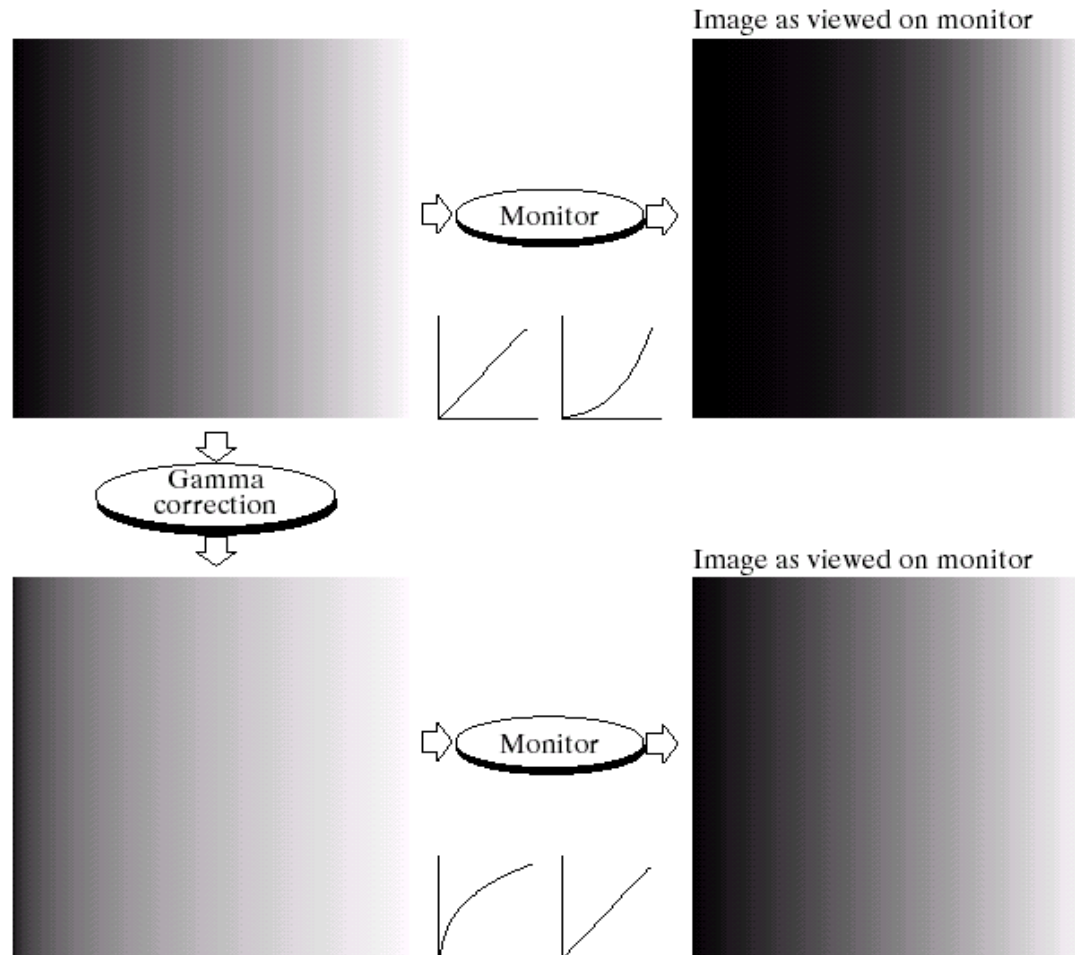

Power Law Transformations Contrast Enhancement

The images to the right show a magnetic resonance (MR) image of a fractured human spine



Power Law Transformations Contrast Enhancement

$$\gamma = 0.6$$

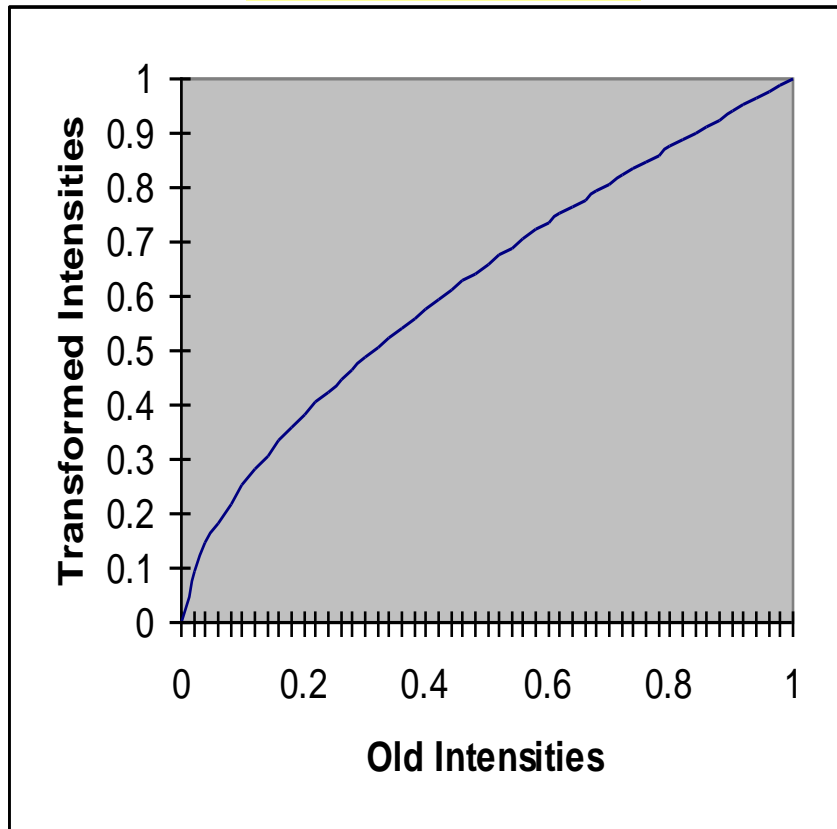

Power Law Transformations Contrast Enhancement

$$\gamma = 0.4$$

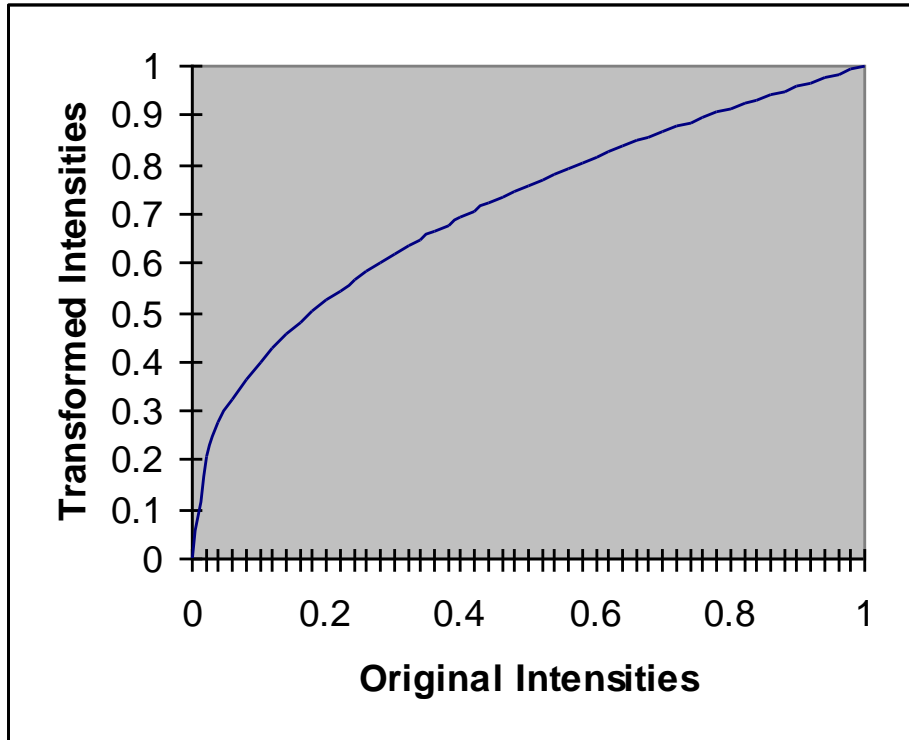

Power Law Transformations Contrast Enhancement

$$\gamma = 0.3$$

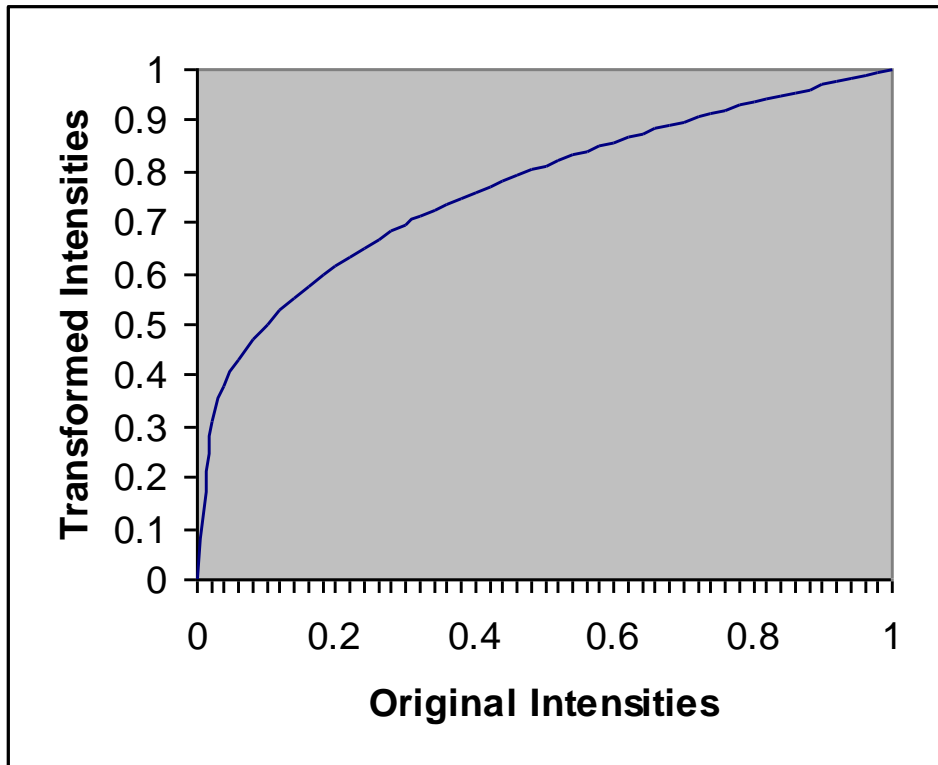

Power Law Transformations

Contrast Enhancement



MR image of
fractured human spine

Result after
Power law
transformation

$$c = 1, \gamma = 0.6$$

Result after
Power law
transformation

$$c = 1, \gamma = 0.4$$

Result after
Power law
transformation

$$c = 1, \gamma = 0.3$$

Power Law Transformations

Contrast Enhancement

When the γ is reduced too much, the image begins to reduce contrast to the point where the image started to have very slight “wash-out” look.

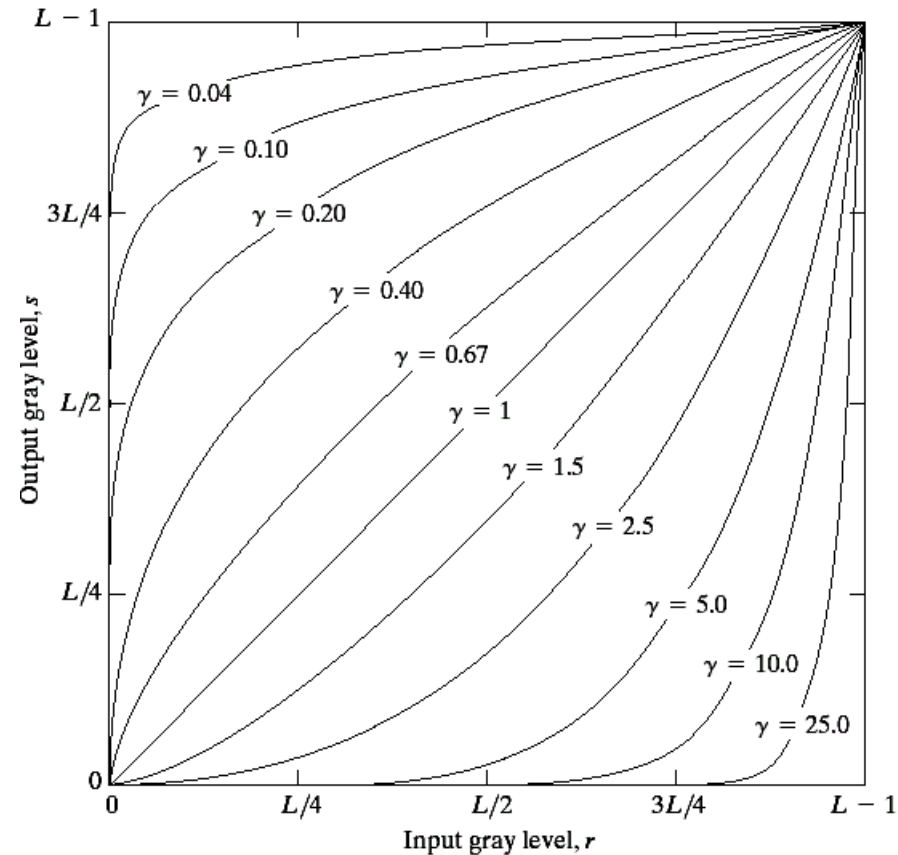

Power Law Transformations Contrast Enhancement

Image has a washed-out appearance – needs $\gamma > 1$



Image Enhancement

Aerial
Image



Result of
Power law
transformation
 $c = 1, \gamma = 3.0$
(suitable)



Result of
Power law
transformation
 $c = 1, \gamma = 4.0$
(suitable)



Result of
Power law
transformation
 $c = 1, \gamma = 5.0$
(high contrast,
some regions are
too dark)



Piecewise Linear Transformation Functions

- ◆ Contrast stretching
- ◆ Intensity level slicing

Contrast Stretching

- ◆ Objective
 - Increase the dynamic range of the gray levels for low contrast images
- ◆ Rather than using a well defined mathematical function we can use arbitrary user-defined transforms

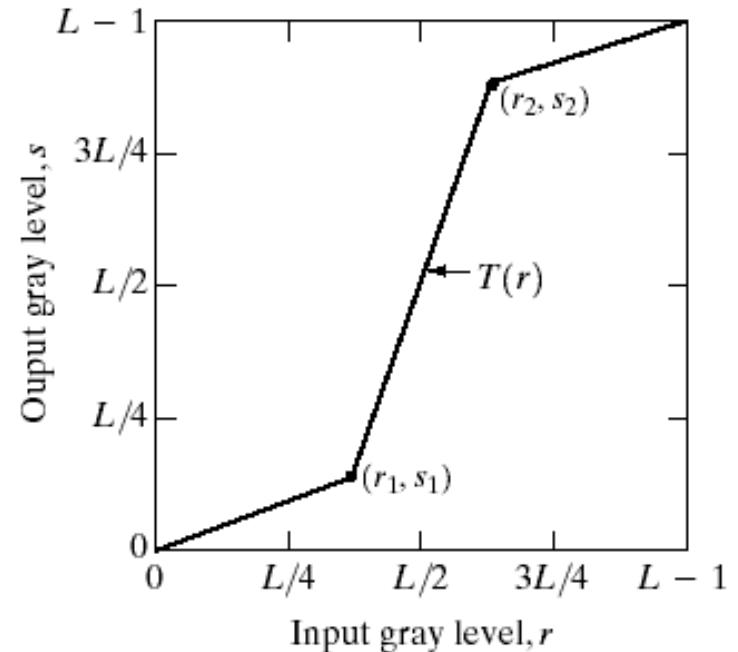

- ◆ If $r_1 = s_1$ & $r_2 = s_2$, no change in gray levels
- ◆ If $r_1 = r_2$, $s_1 = 0$ & $s_2 = L-1$, then it is a threshold function. The resulting image is binary

Contrast Stretching

$$r_1 = r_{min} \text{ \& } s_1 = 0$$
$$r_2 = r_{max} \text{ \& } s_2 = L-1$$

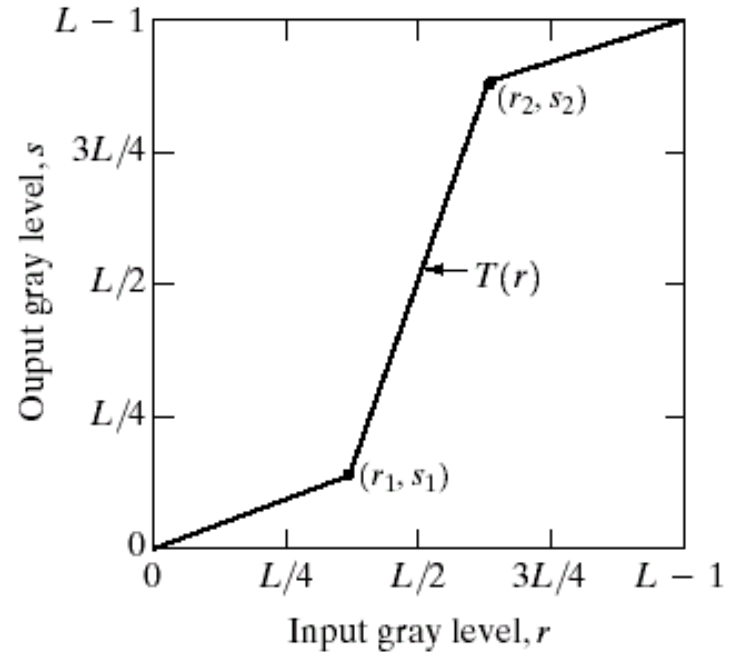

Contrast Stretching

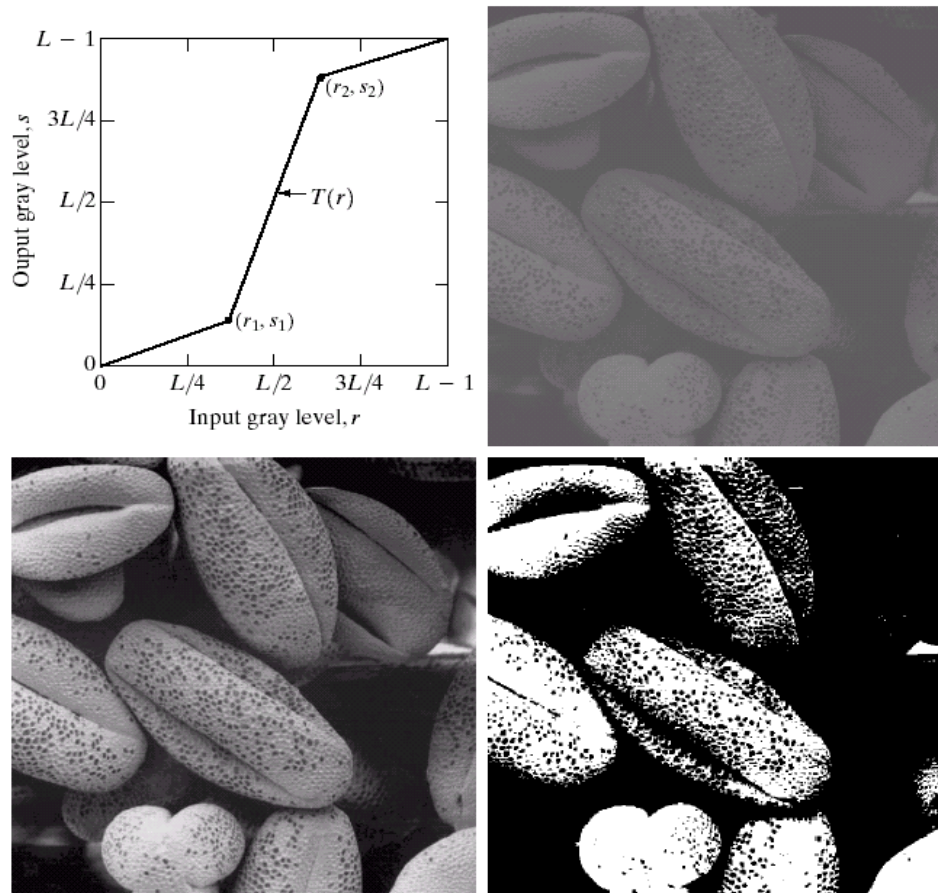

a b
c d

FIGURE 3.10
Contrast stretching. (a) Form of transformation function. (b) A low-contrast image. (c) Result of contrast stretching. (d) Result of thresholding. (Original image courtesy of Dr. Roger Heady, Research School of Biological Sciences, Australian National University, Canberra, Australia.)

Grey Level Slicing

- ◆ Highlights a specific range of gray levels in an image
 - Similar to thresholding
 - Other levels can be suppressed or maintained
 - Useful for highlighting features in an image

Grey Level Slicing

Highlights range [A,B] of gray levels and reduces all others to a contrast level

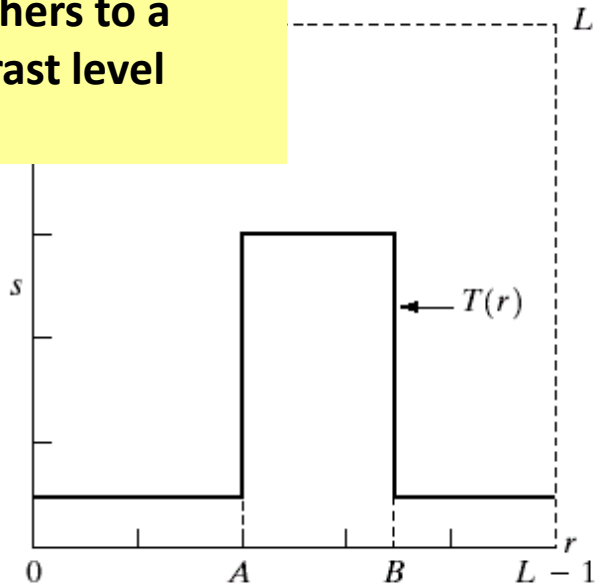

Highlights range [A,B] but preserves all other gray levels

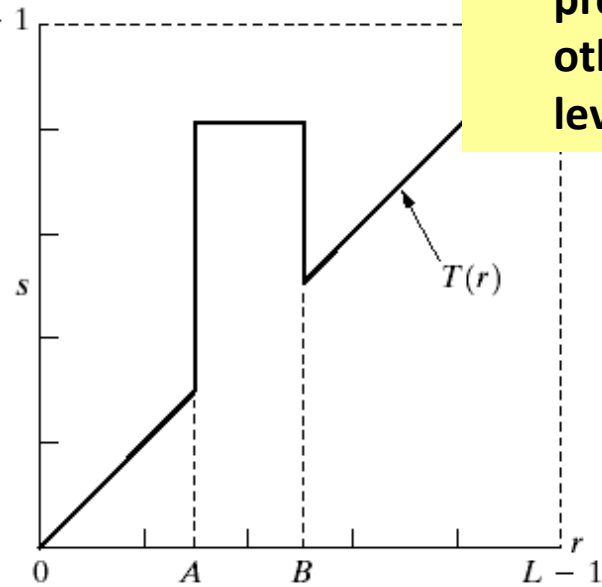

Grey Level Slicing

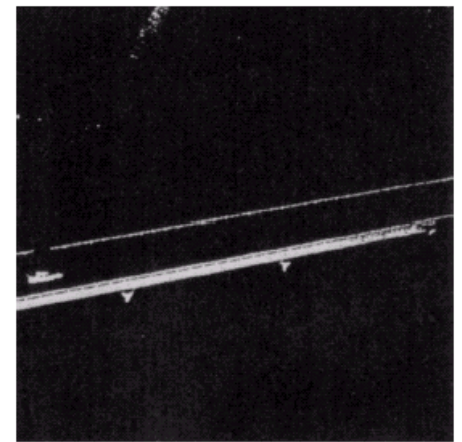
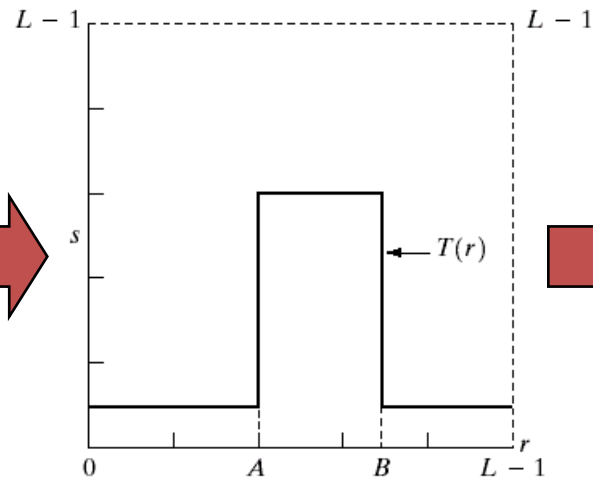
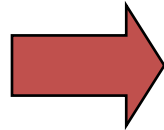
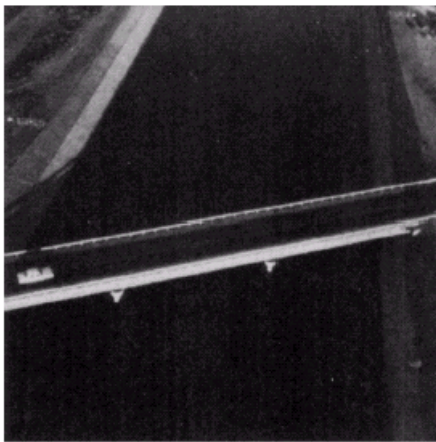

Bit Plane Slicing

- Often by isolating particular bits of the pixel values in an image we can highlight interesting aspects of that image
 - Higher-order bits usually contain most of the significant visual information
 - Lower-order bits contain subtle details

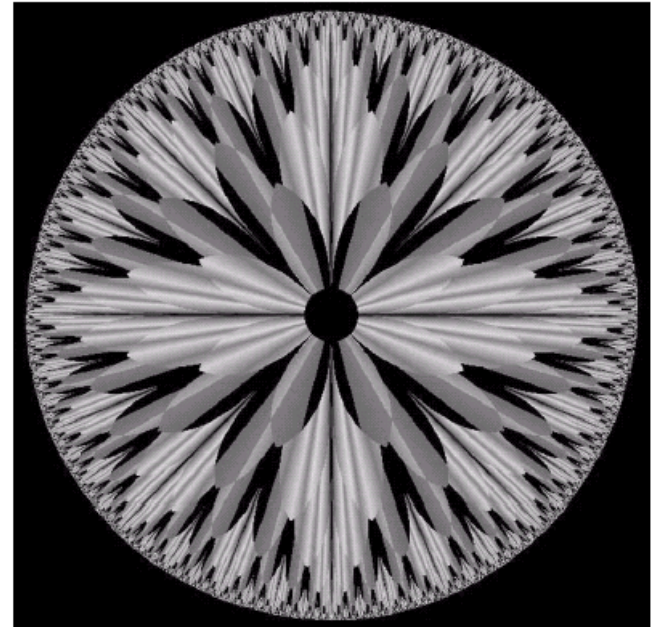
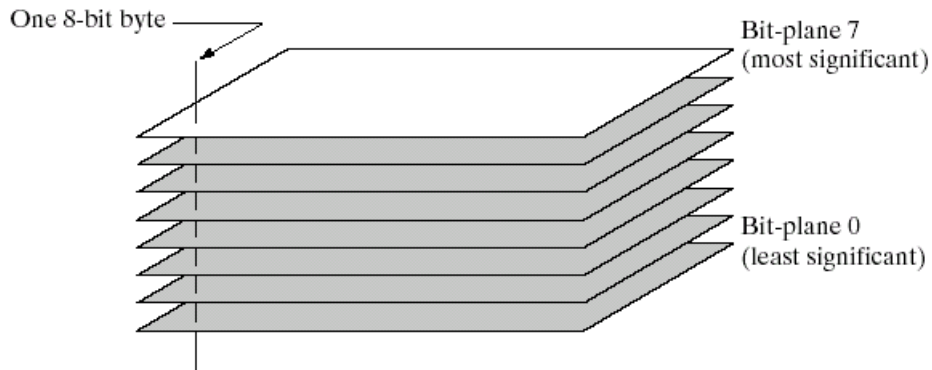

8 bit planes

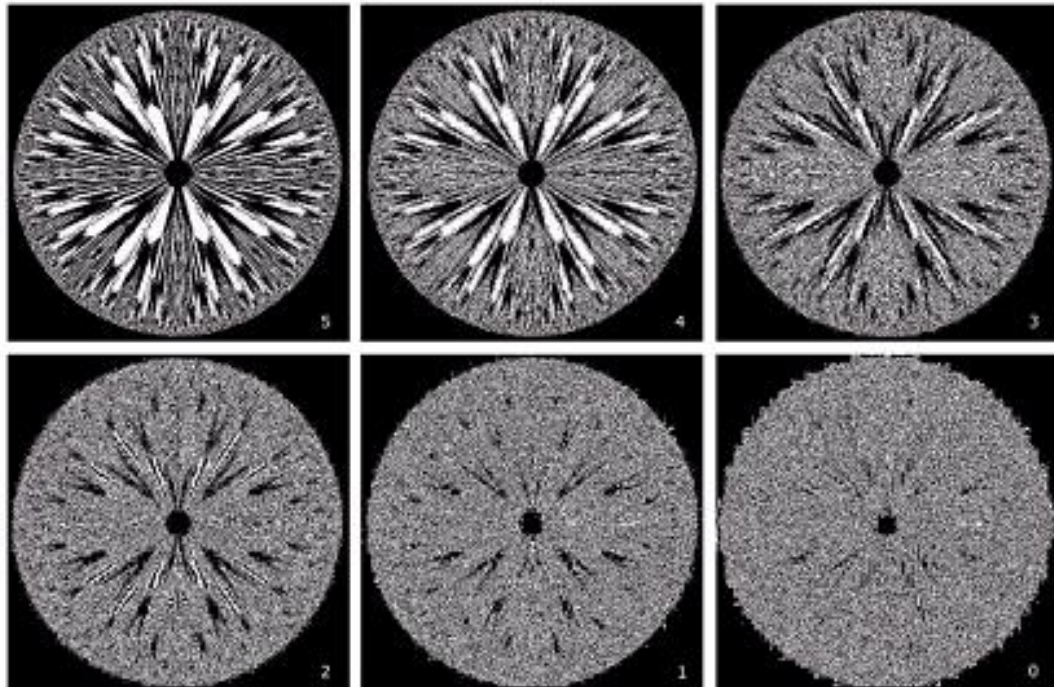
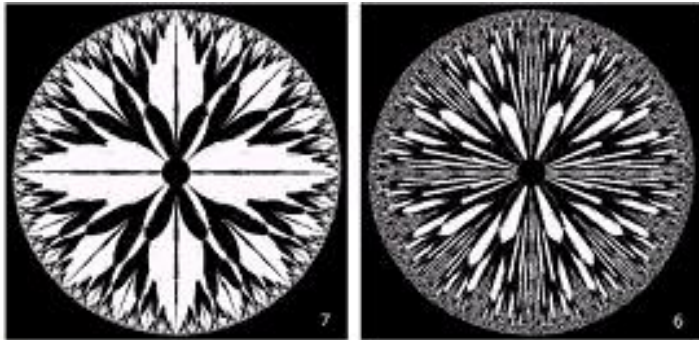

Bit-plane 7		Bit-plane 6	
Bit-plane 5	Bit-plane 4	Bit-plane 3	
Bit-plane 2	Bit-plane 1	Bit-plane 0	

Bit Plane Slicing Example

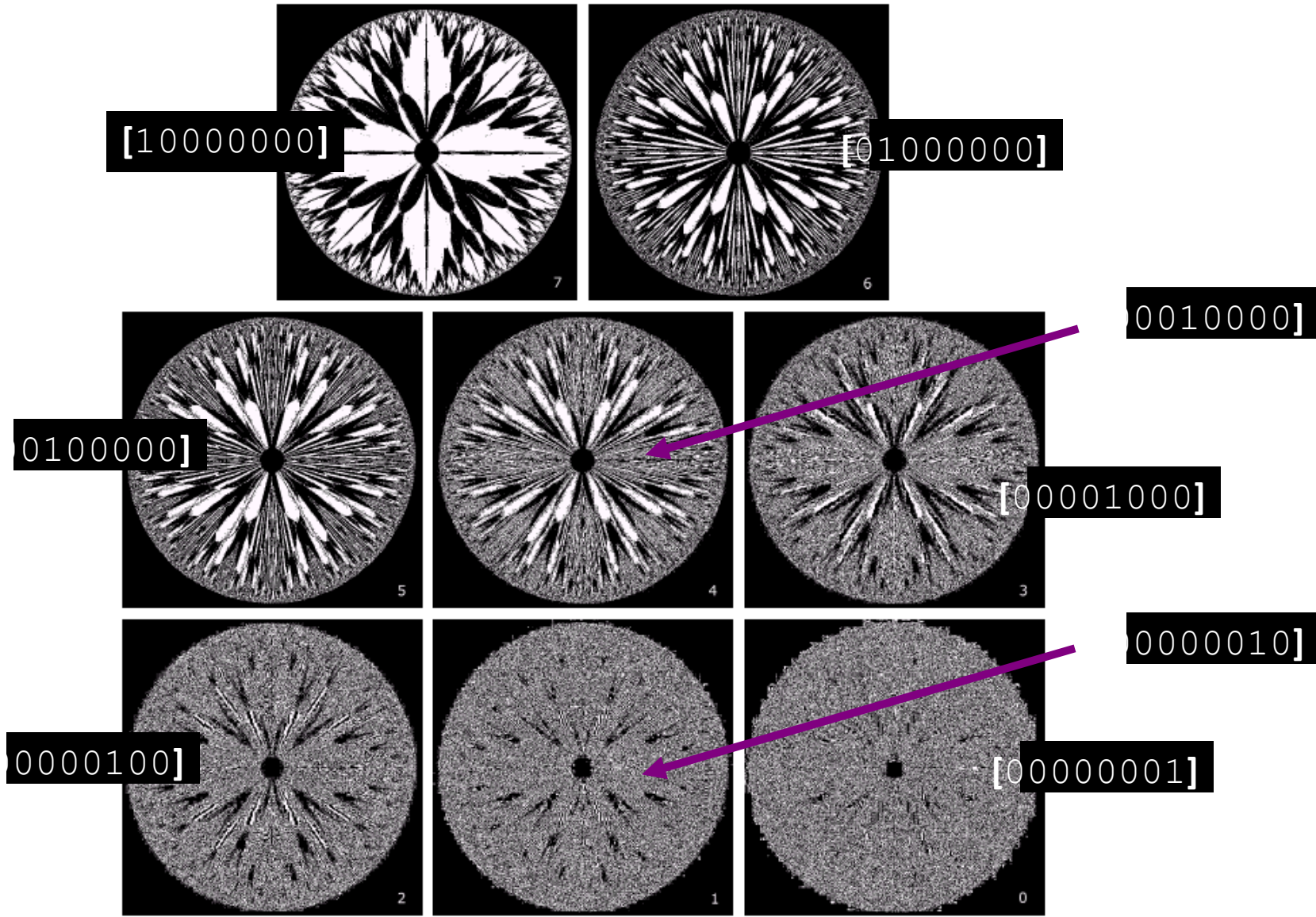

Bit Plane Slicing (cont...)



a	b	c
d	e	f
g	h	i

FIGURE 3.14 (a) An 8-bit gray-scale image of size 500×1192 pixels. (b) through (i) Bit planes 1 through 8, with bit plane 1 corresponding to the least significant bit. Each bit plane is a binary image.

Bit Plane Slicing (cont...)



Reconstructed image using only bit planes 8 and 7



Reconstructed image using only bit planes 8, 7 and 6



Reconstructed image using only bit planes 7, 6 and 5

Histogram of a Grayscale Image

- ◆ Let I be a 1-band (grayscale) image.
- ◆ $I(r,c)$ is an 8-bit integer between 0 and 255.
- ◆ Histogram, h_I , of I :
 - a 256-element array, h_I
 - $h_I(g)$ = number of pixels in I that have value g .
for $g = 0, 1, 2, 3, \dots, 255$

HISTOGRAM

- A discrete function $h(r_k)=n_k$
 - r_k is the k^{th} gray level
 - n_k is the number of pixels having gray level r_k in the image
- Ex:

0	1	2	3
1	3	3	0
0	1	3	0
3	0	3	1

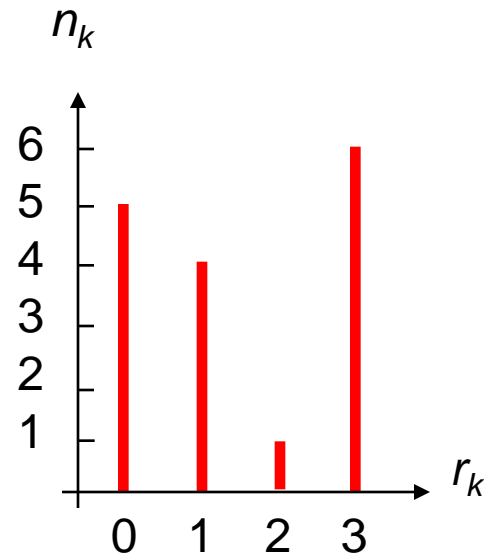

UNIQUENESS



Unique

Non-unique

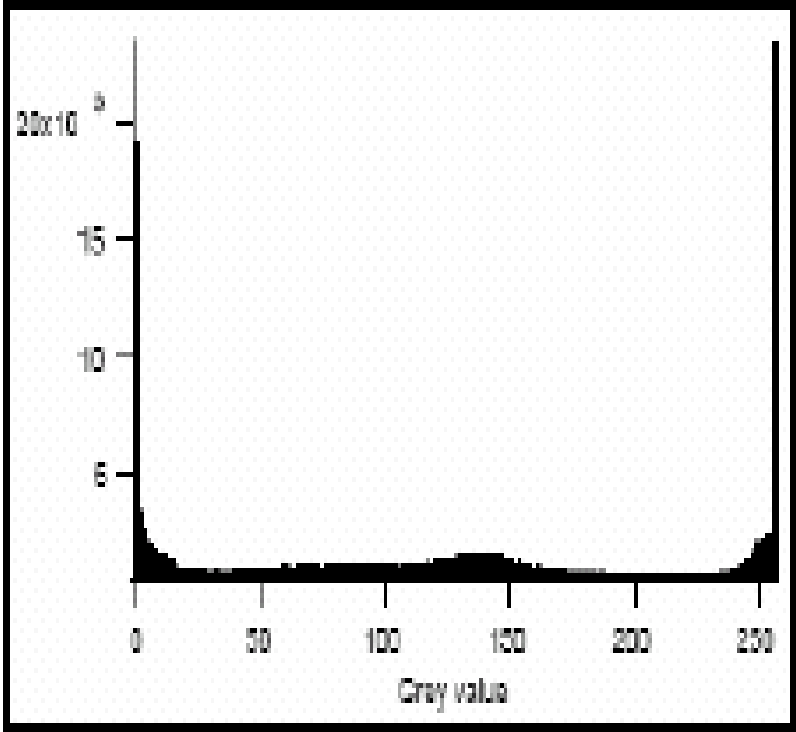

Histogram of a Grayscale Image

- ◆ Histogram of a digital image with gray levels in the range $[0, L-1]$ is a discrete function

$$h(r_k) = n_k$$

Where

- $r_k = k^{\text{th}}$ gray level
- $n_k =$ number of pixels in the image having gray level r_k
- $h(r_k) =$ histogram of an image having r_k gray levels

Normalized Histogram

- ◆ Dividing each of histogram at gray level r_k by the total number of pixels in the image, n

$$p(r_k) = n_k / n \quad \text{for } k = 0, 1, \dots, L-1$$

- ◆ $p(r_k)$ gives an estimate of the probability of occurrence of gray level r_k
- ◆ The sum of all components of a normalized histogram is equal to 1

Histogram of a Grayscale Image



16-level (4-bit) image

lower RHC: number of pixels with intensity g

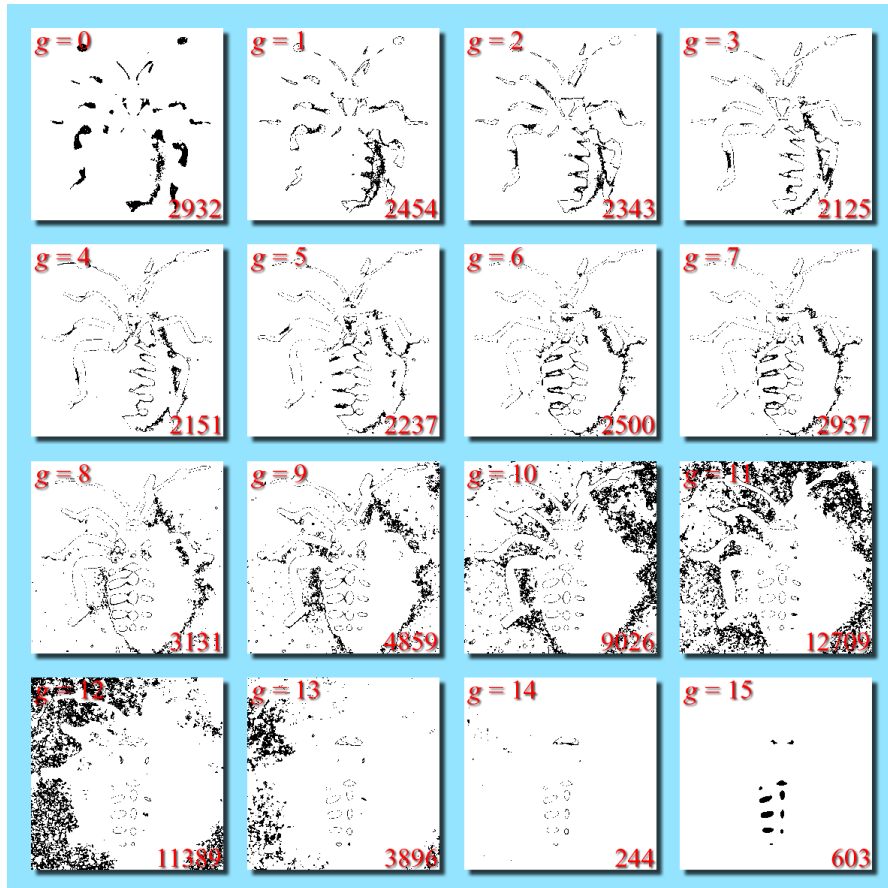

black marks pixels with intensity g

Histogram of a Grayscale Image

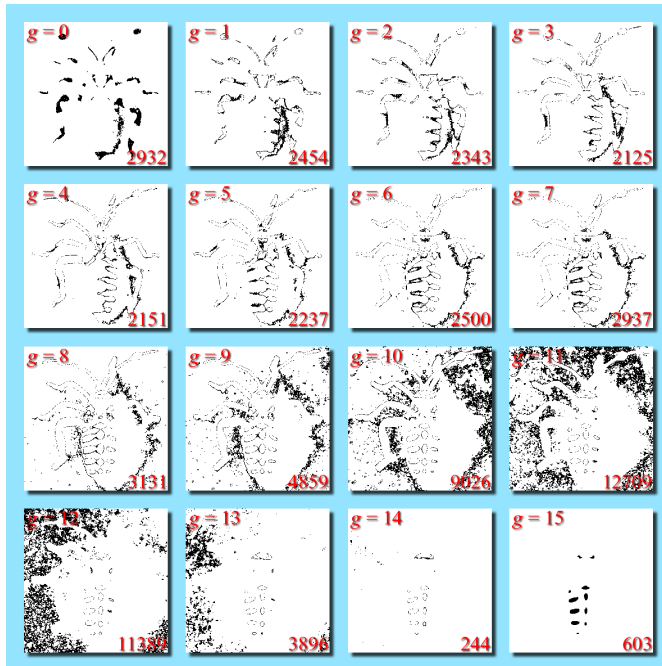

Black marks
pixels with
intensity g

Plot of histogram:
number of pixels with intensity g

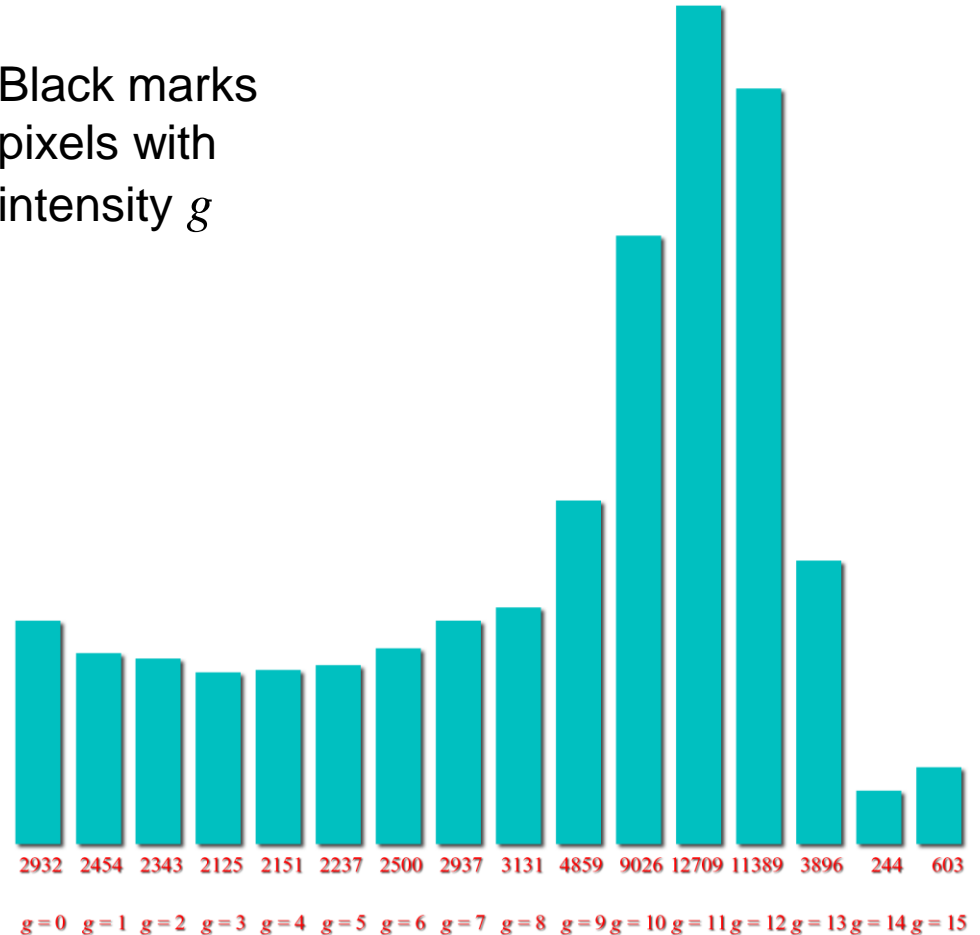

Histogram of a Grayscale Image

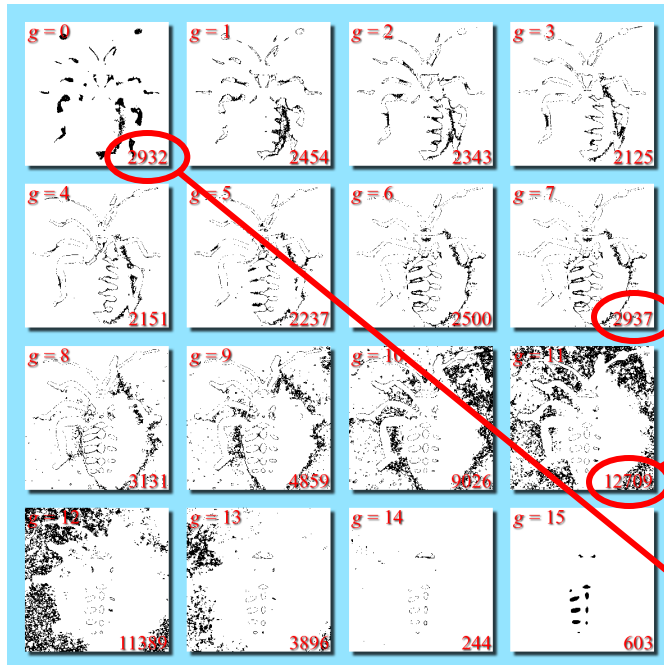

Black marks
pixels with
intensity g

Plot of histogram:
number of pixels with intensity g

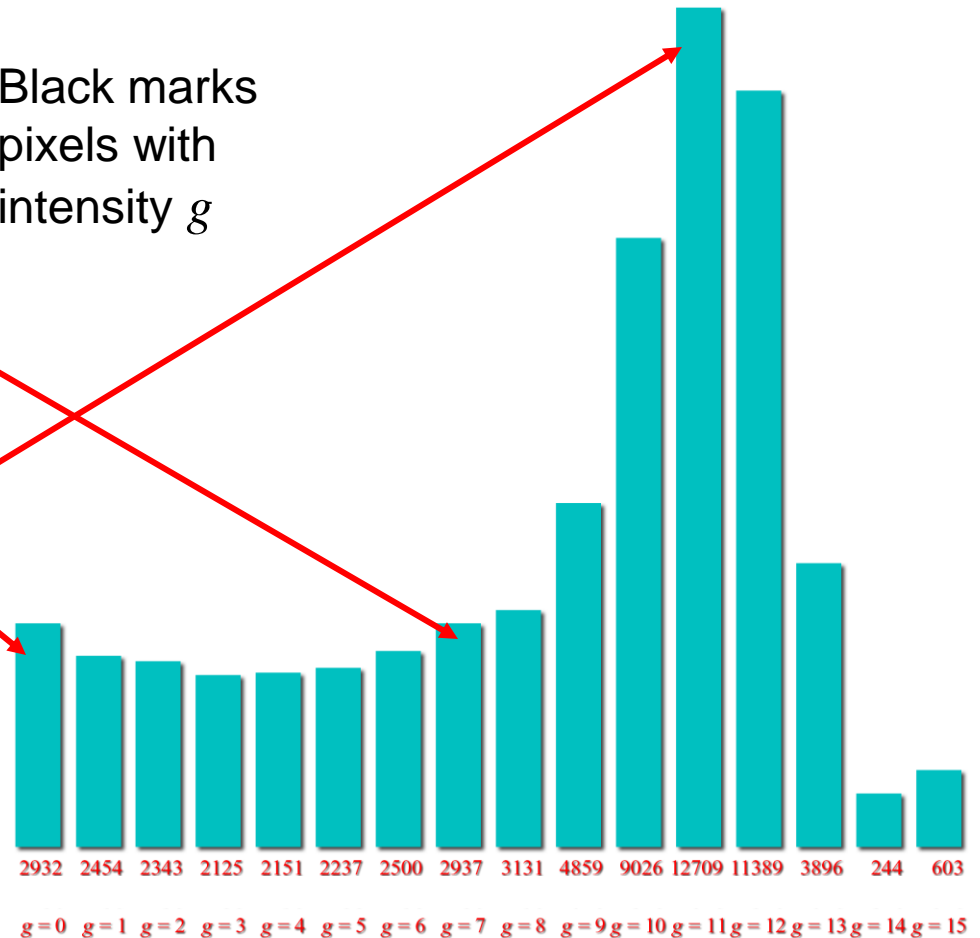

Histogram of a Grayscale Image



$h_I(g) =$ the number of pixels in I with graylevel g .

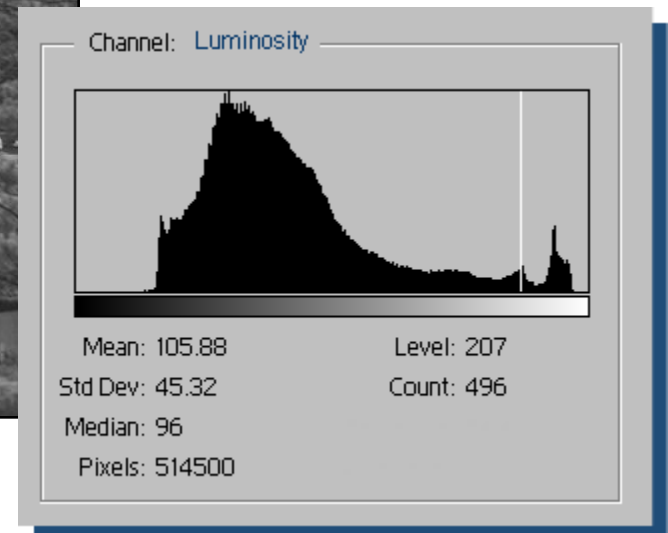

Histogram of a Color Image

- ◆ If I is a 3-band image
- ◆ then $I(r,c,b)$ is an integer between 0 and 255.
- ◆ I has 3 histograms:
 - $h_R(g)$ = # of pixels in $I(:, :, 1)$ with intensity value g
 - $h_G(g)$ = # of pixels in $I(:, :, 2)$ with intensity value g
 - $h_B(g)$ = # of pixels in $I(:, :, 3)$ with intensity value g

Histogram of a Color Image

There is one histogram per color band R, G, & B. Luminosity histogram is from 1 band = $(R+G+B)/3$

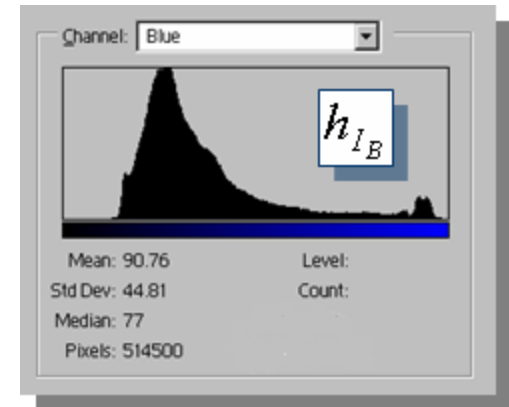
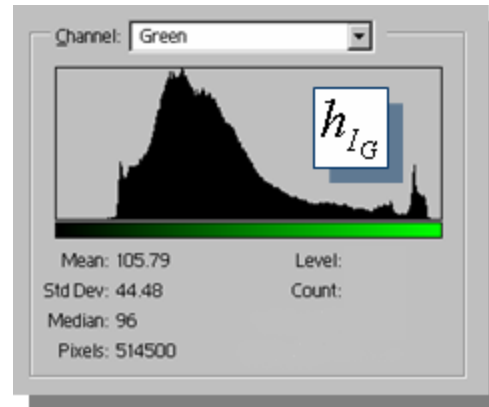
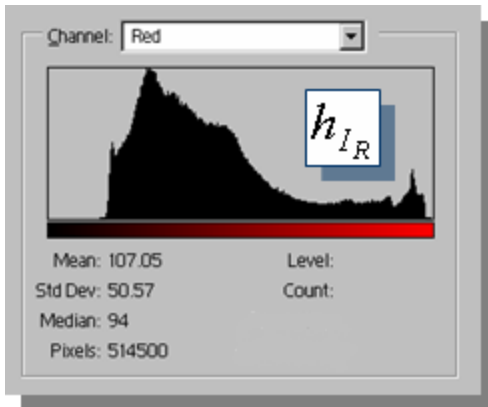
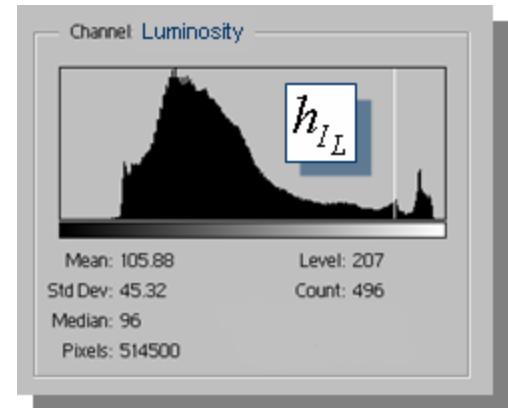

Histogram of a Color Image

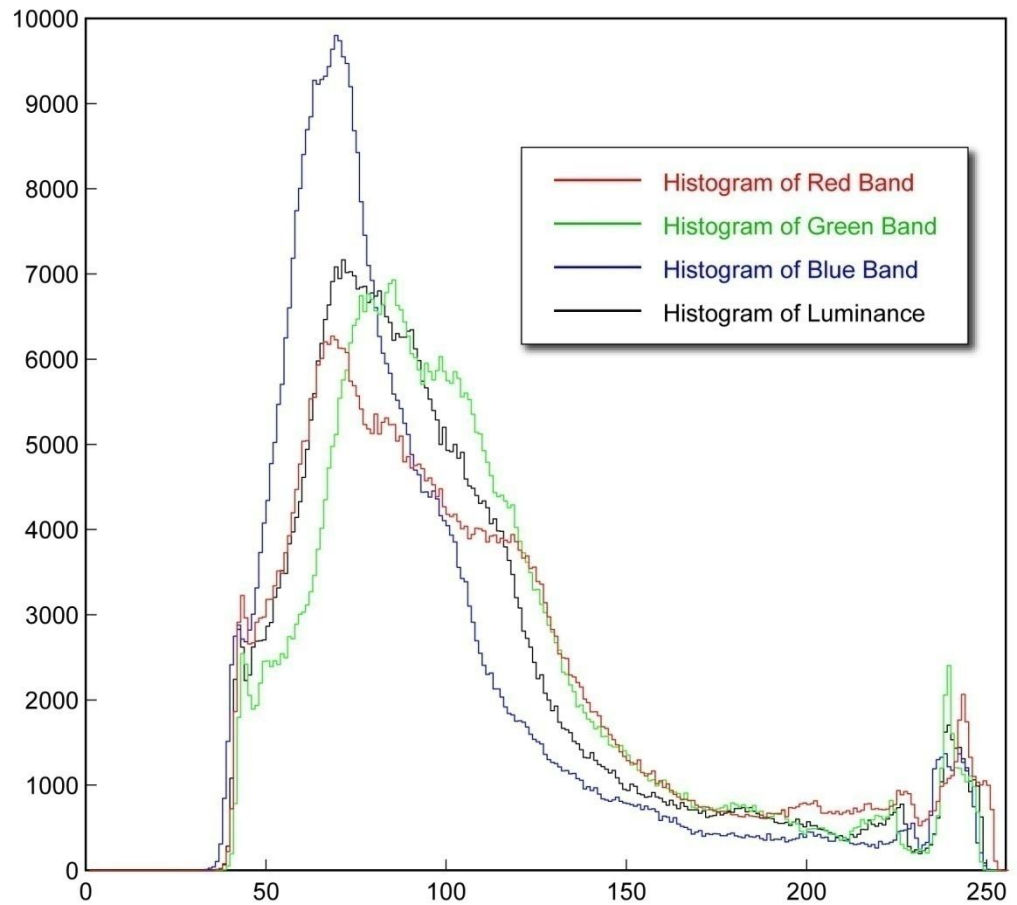

Histogram of a Color Image

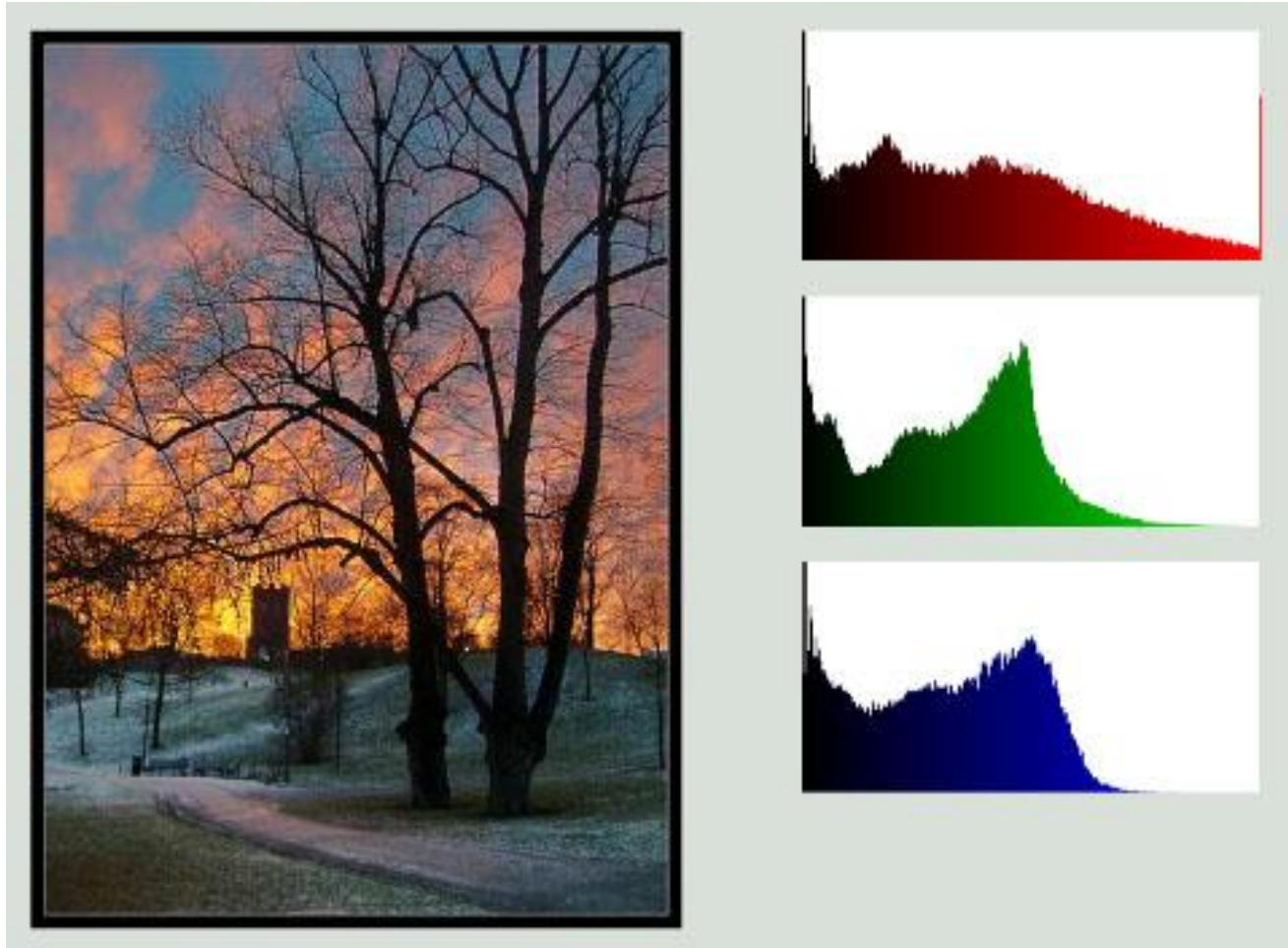

Histogram: Example

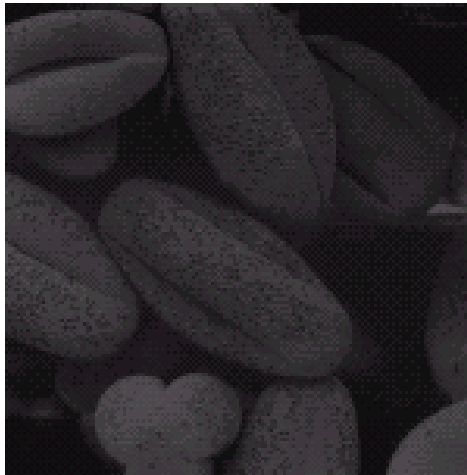

← Dark Image

How would the histograms of these images look like?



← Bright Image

Histogram: Example

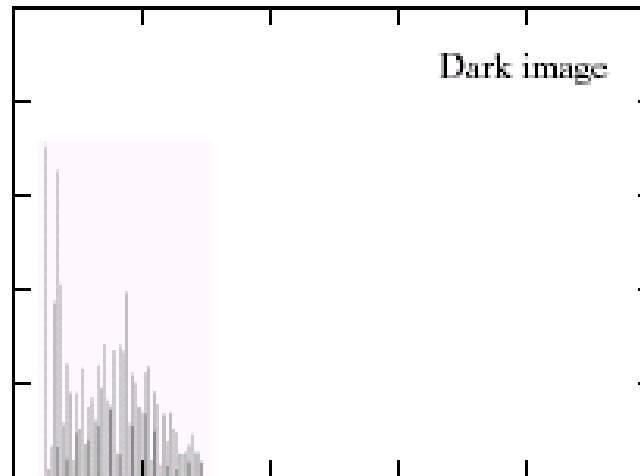
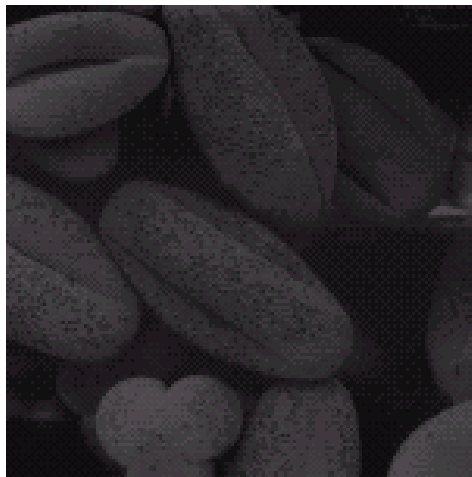

Dark image

Components of histogram are concentrated on the low side of the gray scale

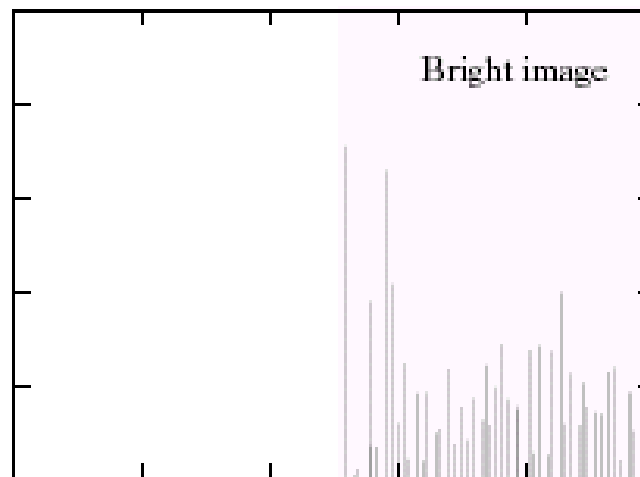

Bright image

Components of histogram are concentrated on the high side of the gray scale

HISTOGRAM INSIGHT INTO CONTRAST

- A high contrast image makes good use of the full dynamic range available.
- Hence in some applications it may be desirable to make more optimal use of the full dynamic range.
- In some circumstances this results in a clearer image.

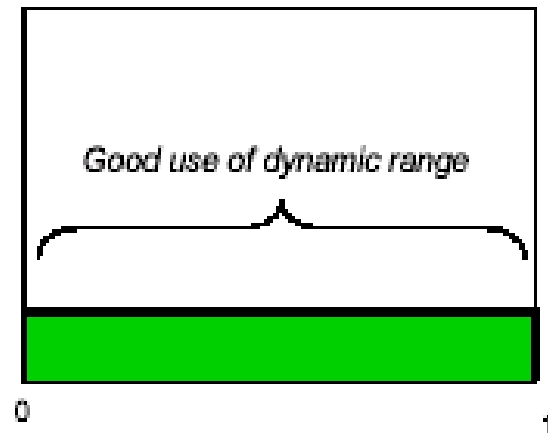
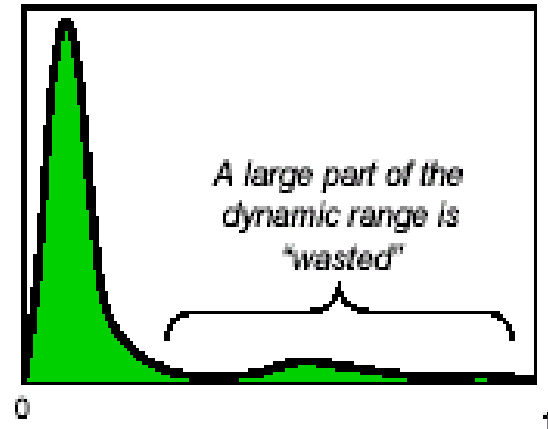

Histogram: Example



Low Contrast Image

How would the histograms of these images look like?



High Contrast Image

Histogram: Example

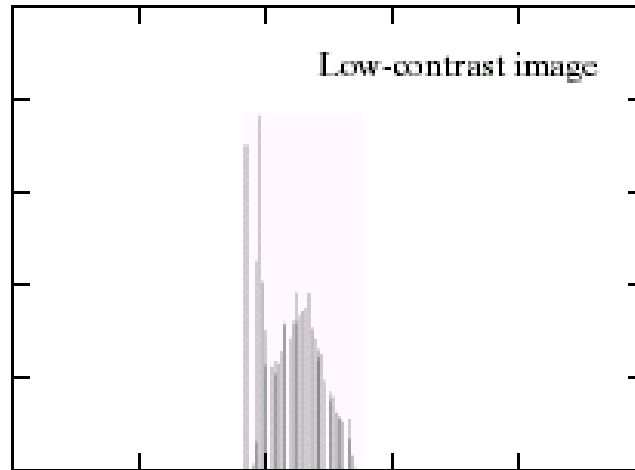
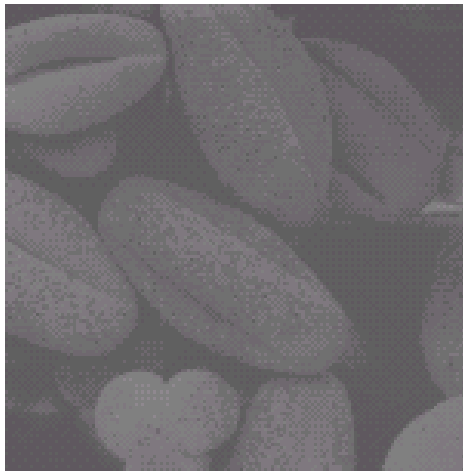

Low contrast image

Histogram is narrow and centered toward the middle of the gray scale

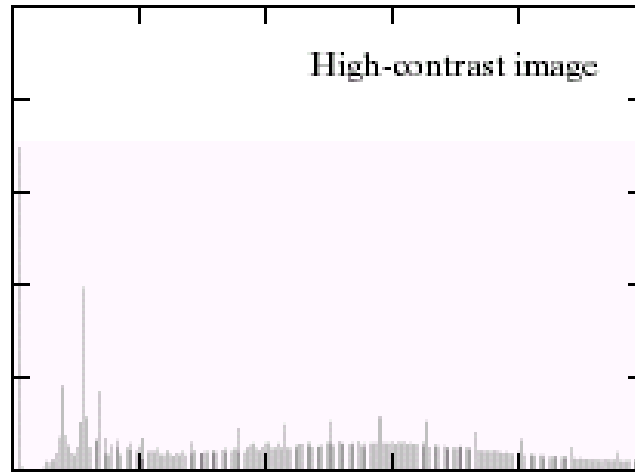

High contrast image

Histogram covers broad range of the gray scale and the distribution of pixels is not too far from uniform with very few vertical lines being much higher than the others

Contrast Stretching

Improve the contrast in an image by `stretching' the range of intensity values it contains to span a desired range of values, *e.g.* the full range of pixel values

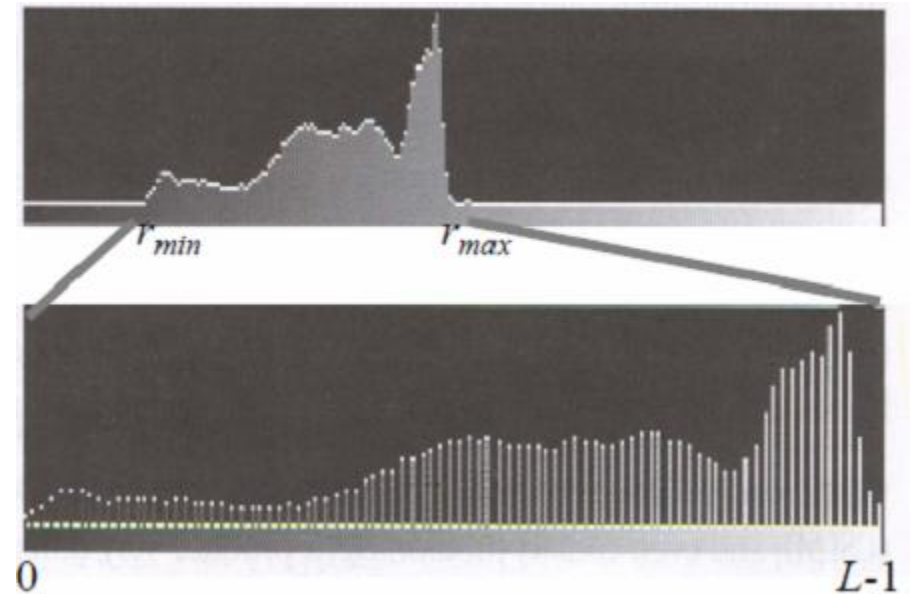

Contrast Stretching

If r_{max} and r_{min} are the maximum and minimum gray level of the input image and L is the total gray levels of output image, the transformation function for contrast stretch will be

$$s = T(r) = (r - r_{min}) \left[\frac{L-1}{r_{max} - r_{min}} \right]$$

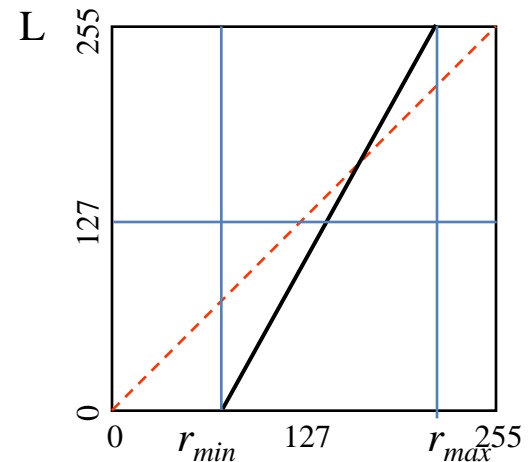

Contrast Stretching

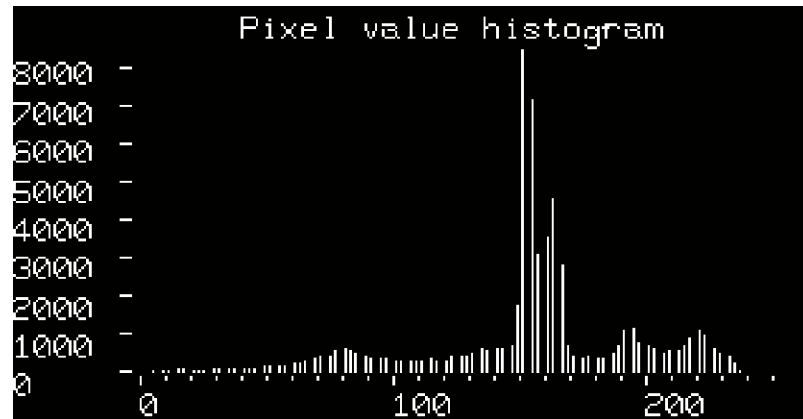
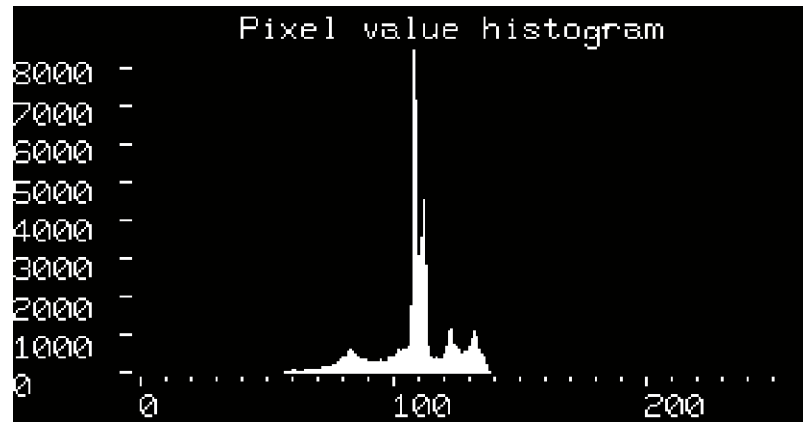

Histogram Equalization

Histogram equalization re-assigns the intensity values of pixels in the input image such that the output image contains a uniform distribution of intensities

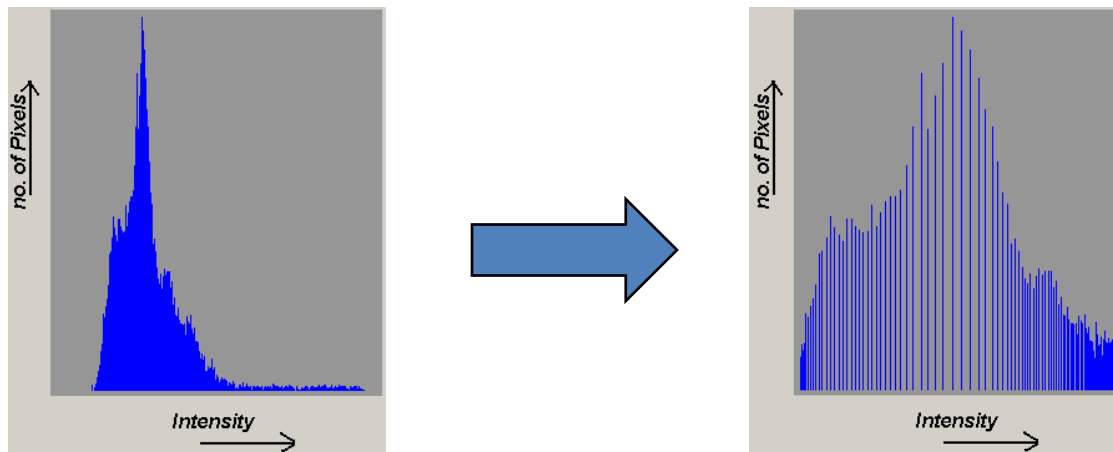

HISTOGRAM EQUALIZATION

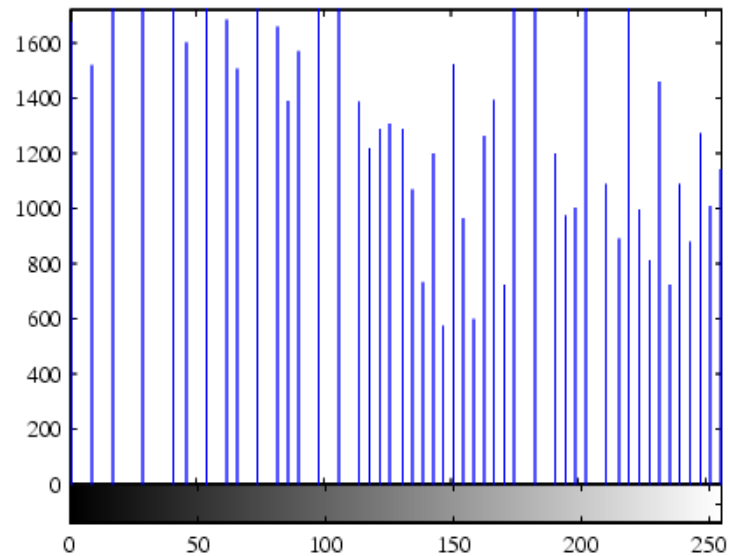
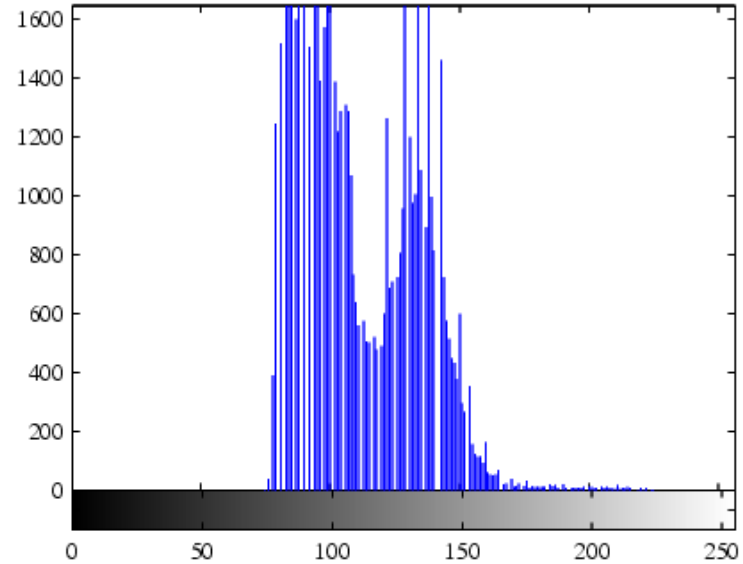

AERIAL PHOTOGRAPH OF THE PENTAGON

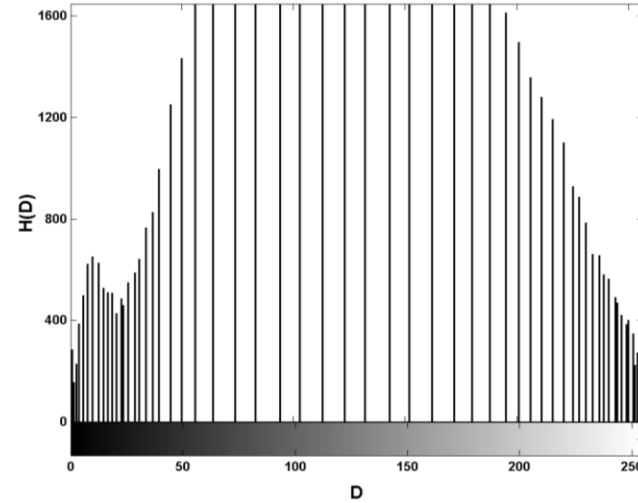
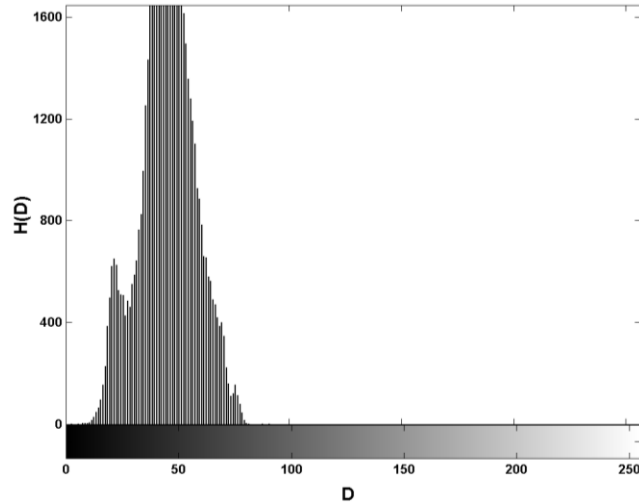

**Resulting image uses more of dynamic range.
Resulting histogram almost, but not completely, flat.**

Acknowledgements

- ◆ Digital Image Processing”, Rafael C. Gonzalez & Richard E. Woods, Addison-Wesley, 2008