

Digital Image Processing

Lecture # 5 **Spatial Enhancement**

Spatial Filtering

Spatial Filtering

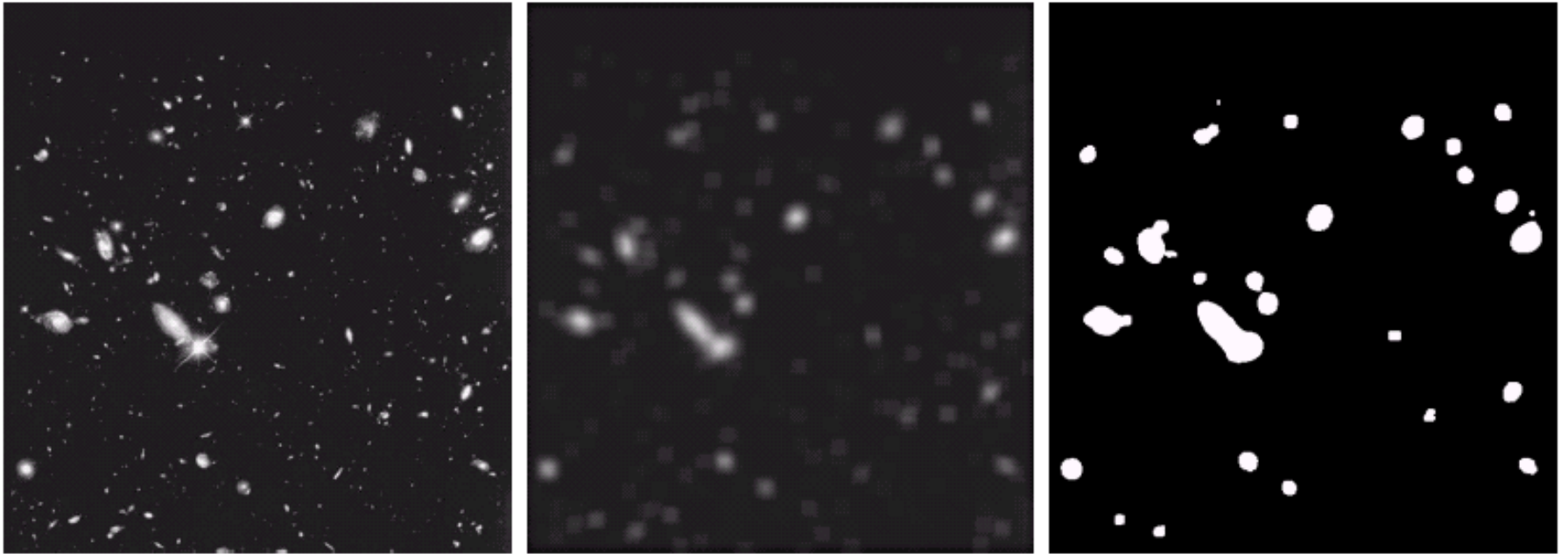

a b c

FIGURE 3.36 (a) Image from the Hubble Space Telescope. (b) Image processed by a 15×15 averaging mask. (c) Result of thresholding (b). (Original image courtesy of NASA.)

Spatial Filtering



a b c

FIGURE 4.50 (a) Original image (784×732 pixels). (b) Result of filtering using a GLPF with $D_0 = 100$. (c) Result of filtering using a GLPF with $D_0 = 80$. Note the reduction in fine skin lines in the magnified sections in (b) and (c).

Spatial Filtering

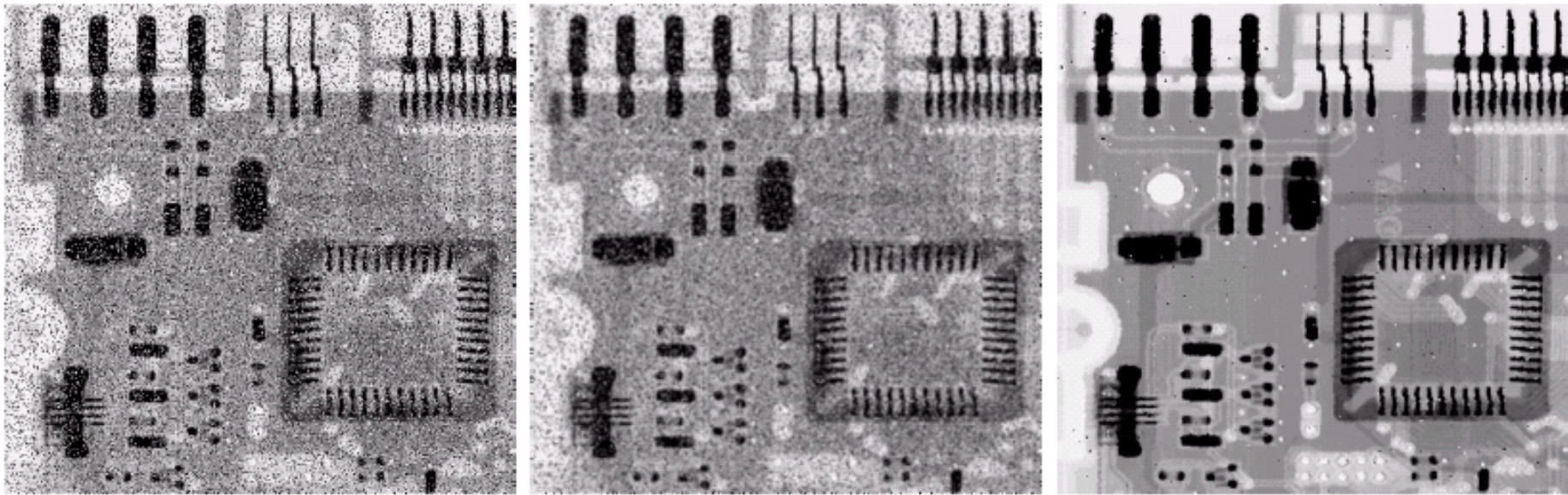

a b c

FIGURE 3.37 (a) X-ray image of circuit board corrupted by salt-and-pepper noise. (b) Noise reduction with a 3×3 averaging mask. (c) Noise reduction with a 3×3 median filter. (Original image courtesy of Mr. Joseph E. Pascente, Lixi, Inc.)

Spatial Filtering

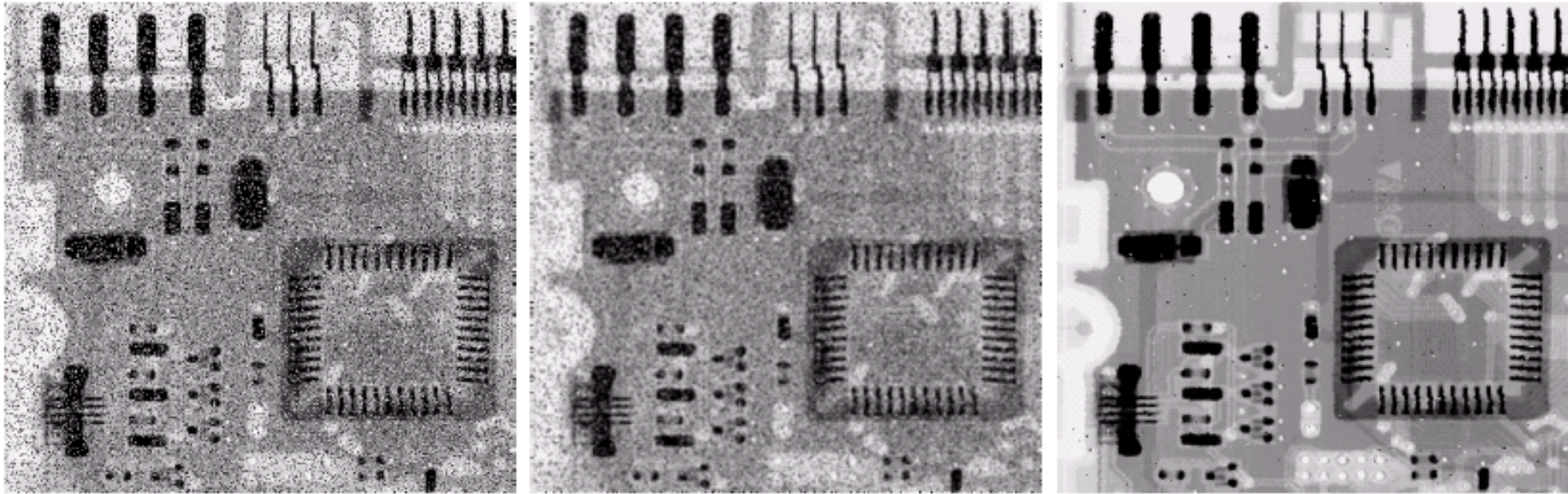

a b c

FIGURE 3.37 (a) X-ray image of circuit board corrupted by salt-and-pepper noise. (b) Noise reduction with a 3×3 averaging mask. (c) Noise reduction with a 3×3 median filter. (Original image courtesy of Mr. Joseph E. Pascente, Lixi, Inc.)

Spatial Filtering

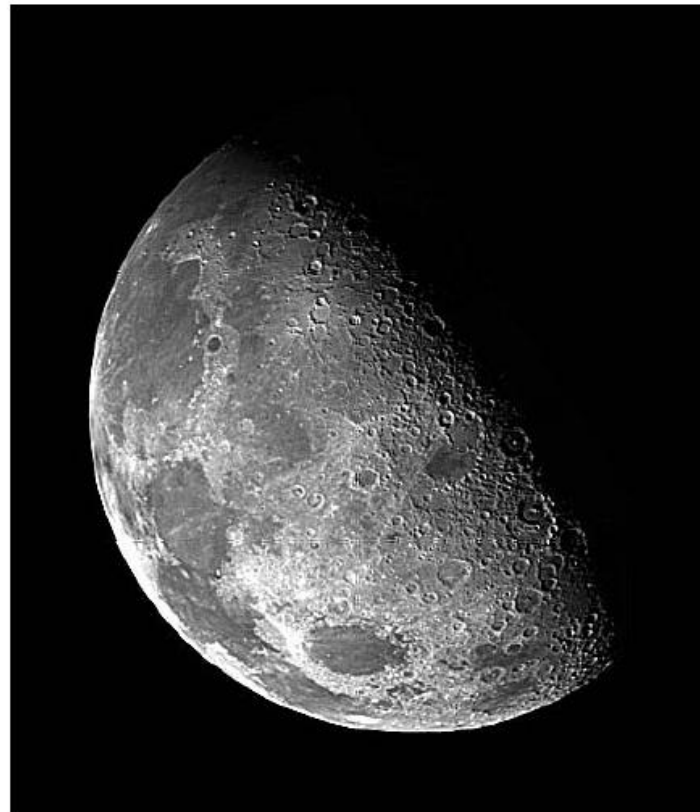

a b

FIGURE 4.58
(a) Original, blurry image.
(b) Image enhanced using the Laplacian in the frequency domain. Compare with Fig. 3.38(e).

Spatial Filtering: Basics

- ◆ The output intensity value at (x,y) depends not only on the input intensity value at (x,y) but also on the specified number of neighboring intensity values around (x,y)
- ◆ Spatial masks (also called window, filter, kernel, template) are used and **convolved** over the entire image for local enhancement (spatial filtering)
- ◆ The size of the masks determines the number of neighboring pixels which influence the output value at (x,y)
- ◆ The values (coefficients) of the mask determine the nature and properties of enhancing technique

Spatial Filtering: Basics

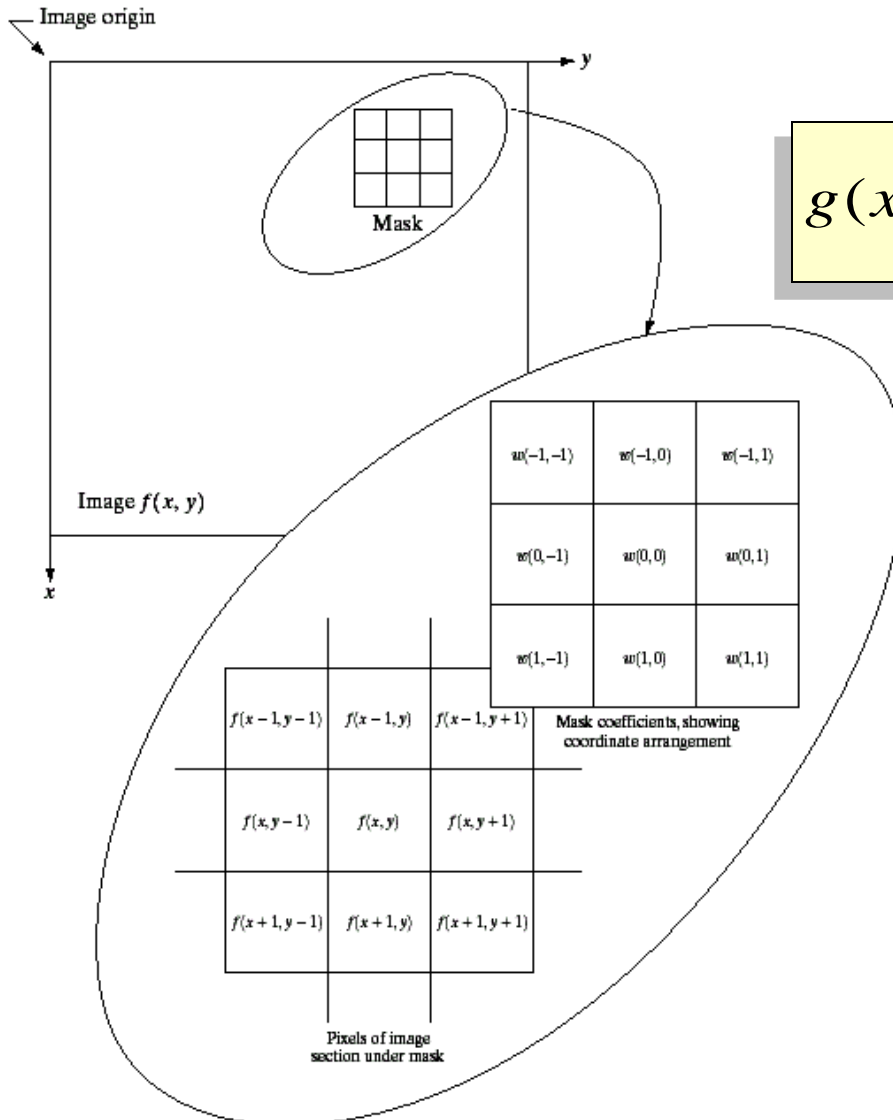

$$g(x, y) = \sum_{s=-a}^a \sum_{t=-b}^b w(s, t) f(x + s, y + t)$$

where $a = \frac{m-1}{2}$, $b = \frac{n-1}{2}$

$x = 0, 1, 2, \dots, M-1, y = 0, 1, 2, \dots, N-1$

Filtering can be given in equation form as shown above

Spatial Filtering: Basics

- ◆ Given the 3×3 mask with coefficients: w_1, w_2, \dots, w_9
- ◆ The mask cover the pixels with gray levels: z_1, z_2, \dots, z_9

w_1	w_2	w_3
w_4	w_5	w_6
w_7	w_8	w_9

z_1	z_2	z_3
z_4	z_5	z_6
z_7	z_8	z_9

$$z \longleftarrow z_1 w_1 + z_2 w_2 + z_3 w_3 + \dots + z_9 w_9 = \sum_{i=1}^9 z_i w_i$$

- ◆ z gives the output intensity value for the processed image (to be stored in a new array) at the location of z_5 in the input image

Convolution Vs Correlation

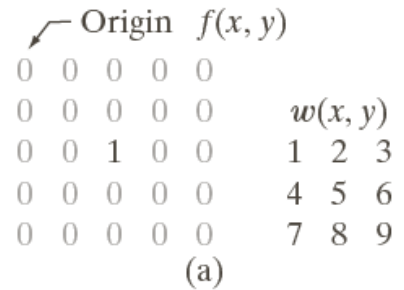
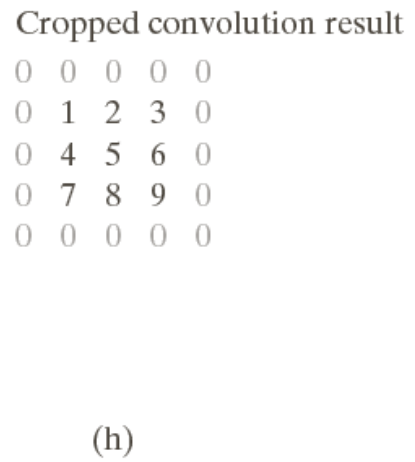
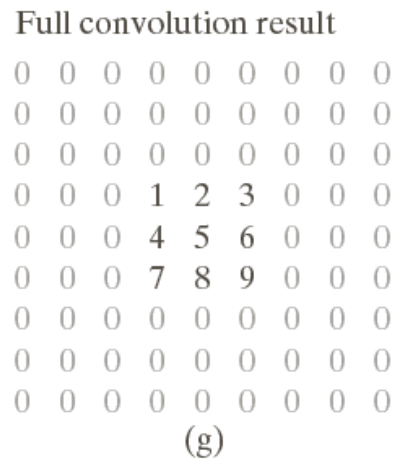
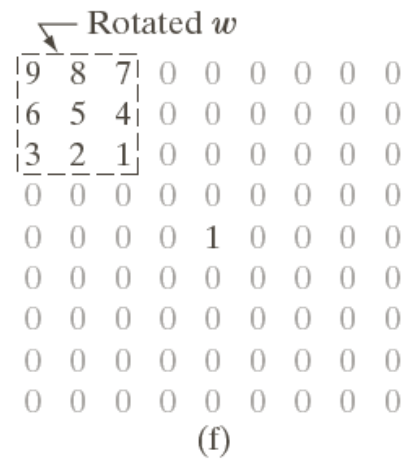
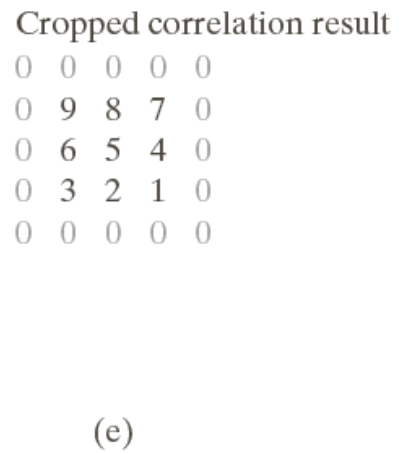
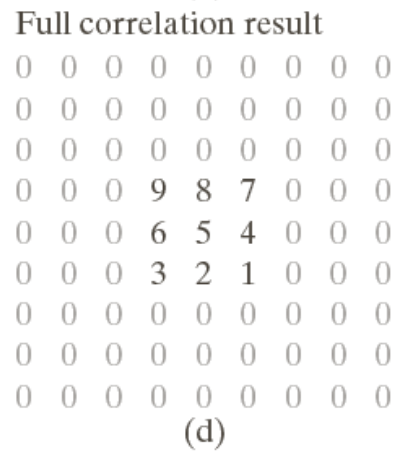
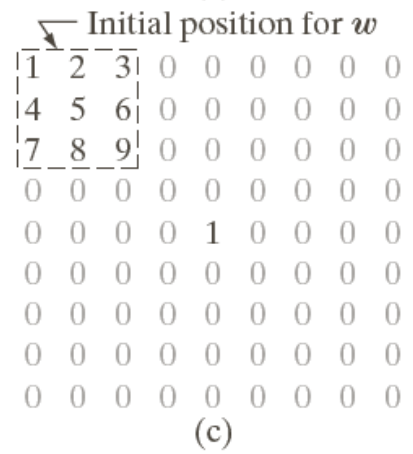

FIGURE 3.30 Correlation (middle row) and convolution (last row) of a 2-D filter with a 2-D discrete, unit impulse. The 0s are shown in gray to simplify visual analysis.



Spatial Filtering: Basics

Neighbourhood operations: Operate on a larger neighbourhood of pixels than point operations

Neighbourhoods are mostly a rectangle around a central pixel

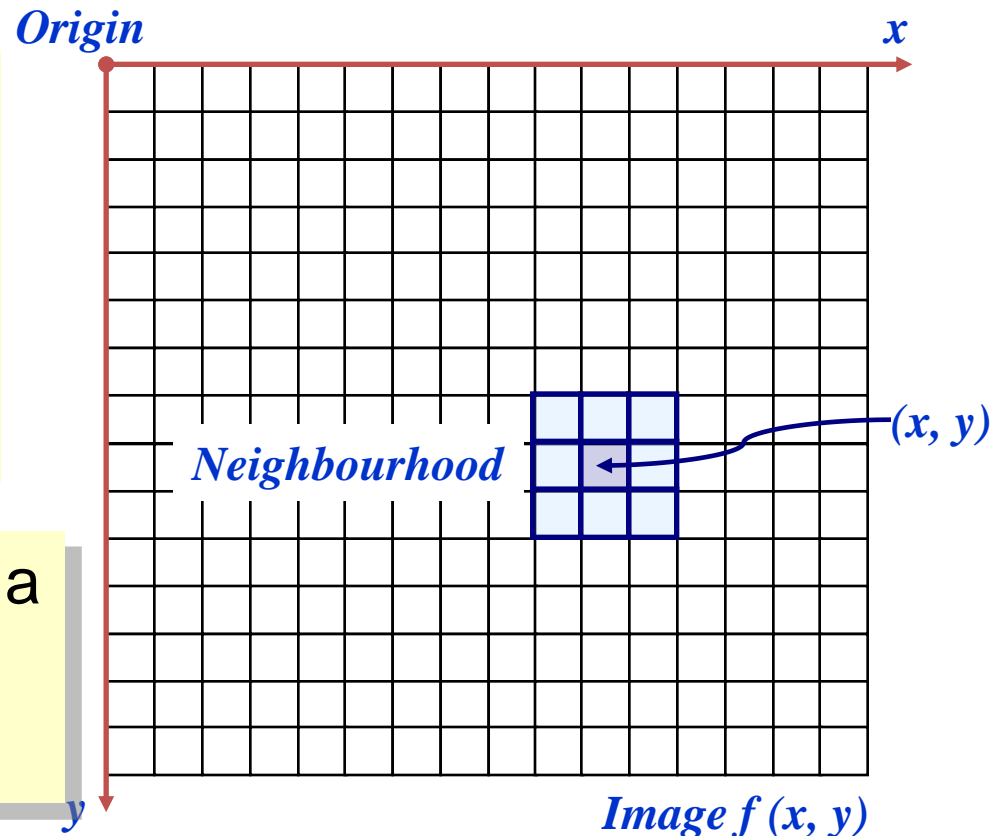

Spatial Filtering: Basics

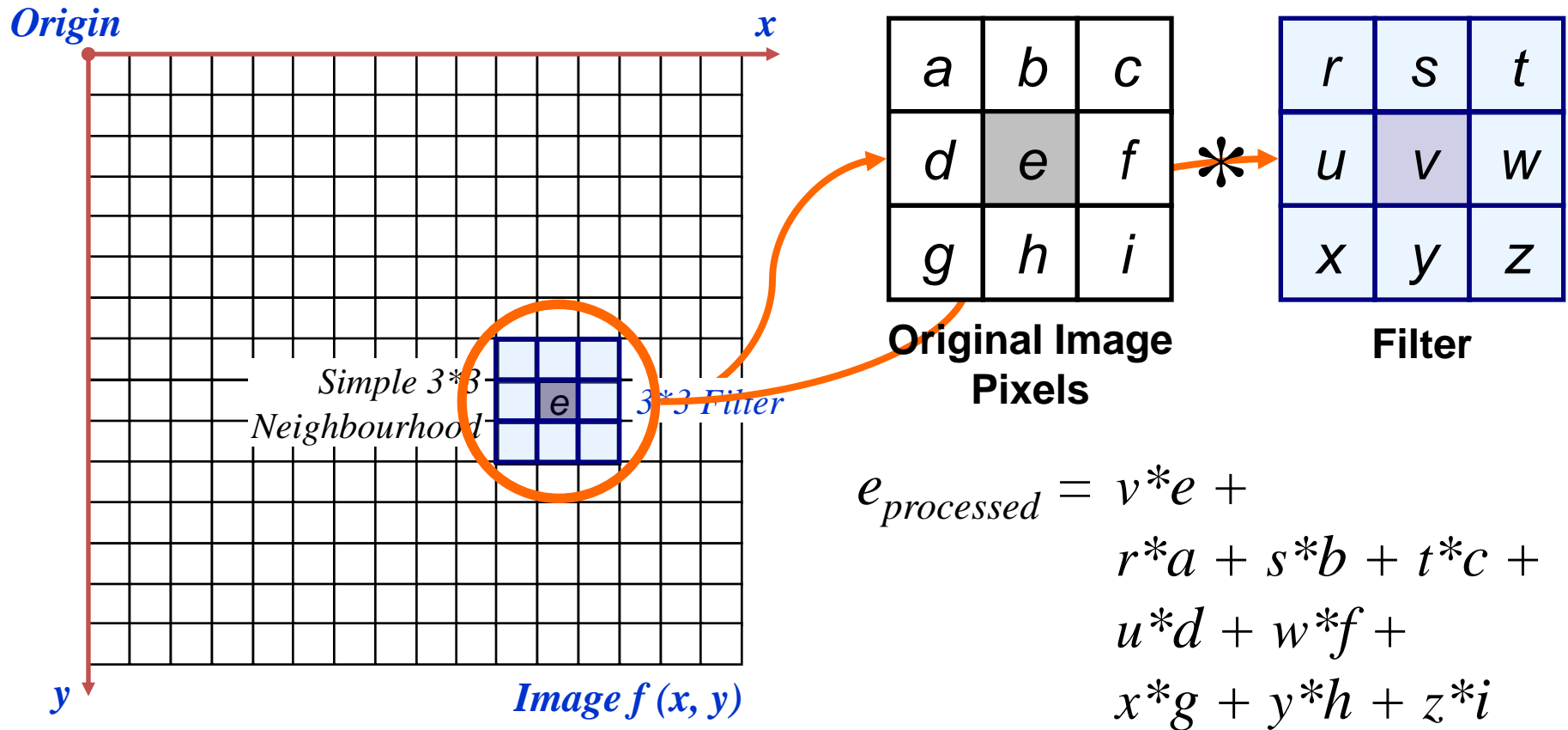

The above is repeated for every pixel in the original image to generate the filtered image

Spatial Filtering: Basics

Original Image

A grid representing the original image with numerical values. The horizontal axis is labeled x and the vertical axis is labeled y . The grid contains the following values:

123	127	128	119	115	130
140	145	148	153	167	172
133	154	183	192	194	191
194	199	207	210	198	195
164	170	175	162	173	151

Vertical ellipsis dots are shown below the grid, and horizontal ellipsis dots are shown to the right of the grid.

Enhanced Image

A grid representing the enhanced image, currently empty. The horizontal axis is labeled x and the vertical axis is labeled y . The grid is identical in size and structure to the original image grid.

Vertical ellipsis dots are shown below the grid, and horizontal ellipsis dots are shown to the right of the grid.

Spatial Filtering: Basics

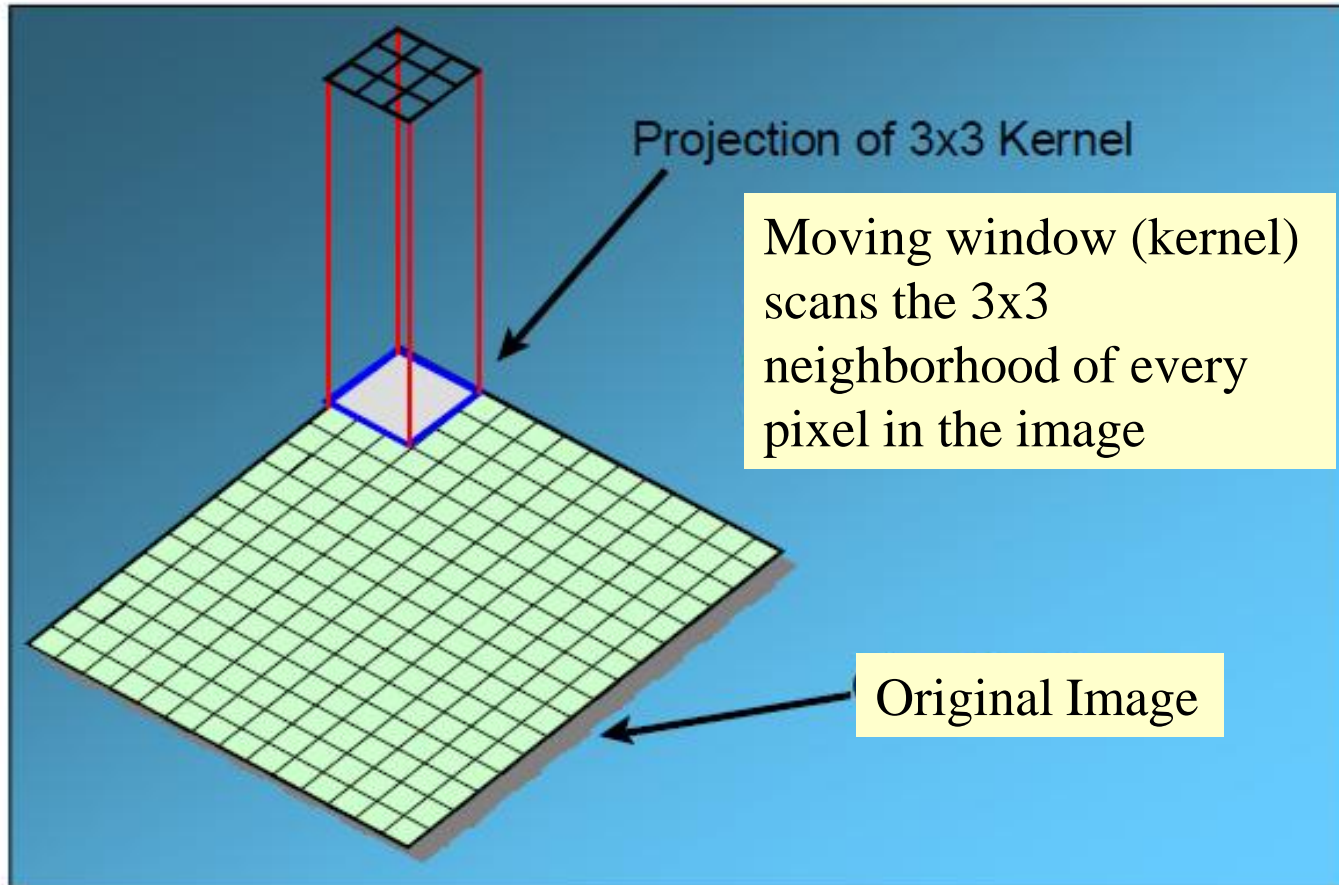

Spatial Filtering: Basics

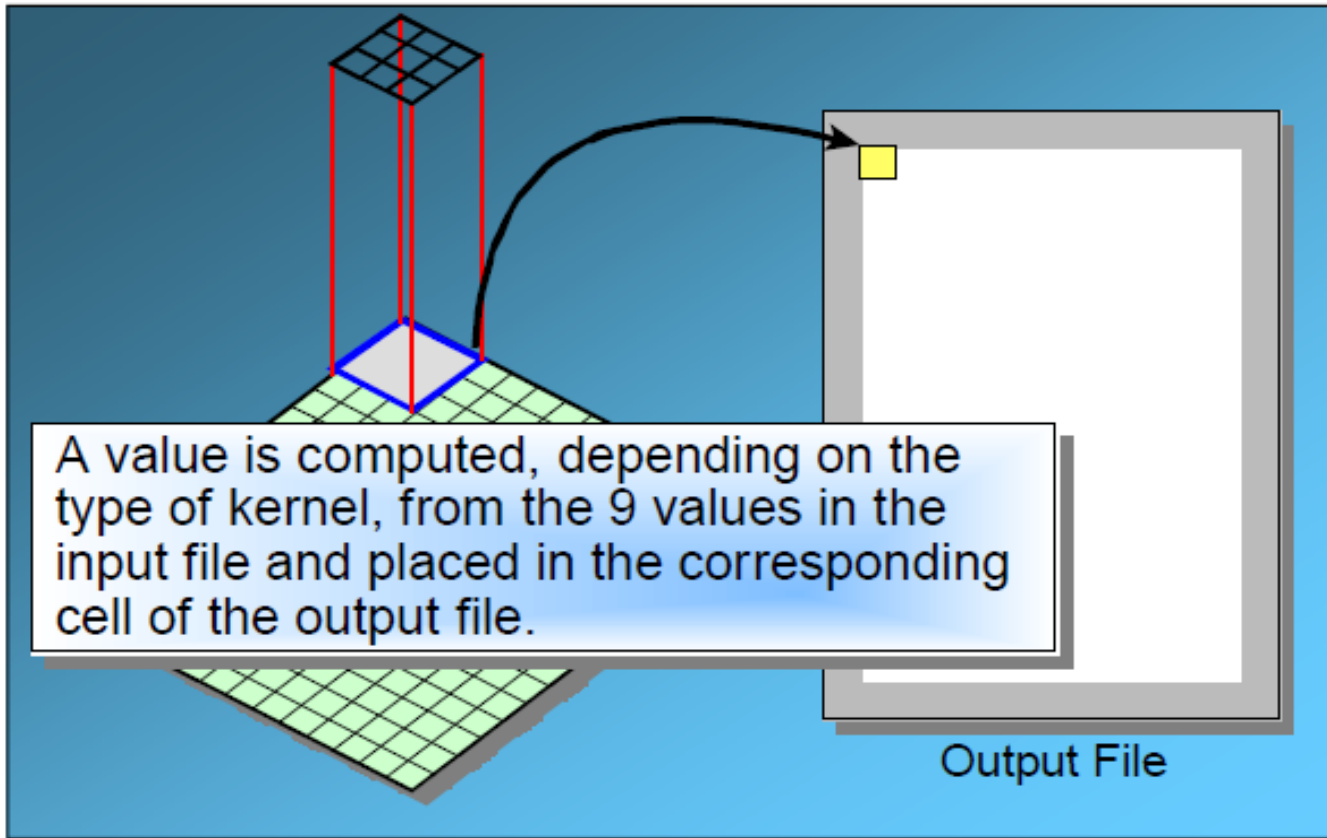

Spatial Filtering: Basics

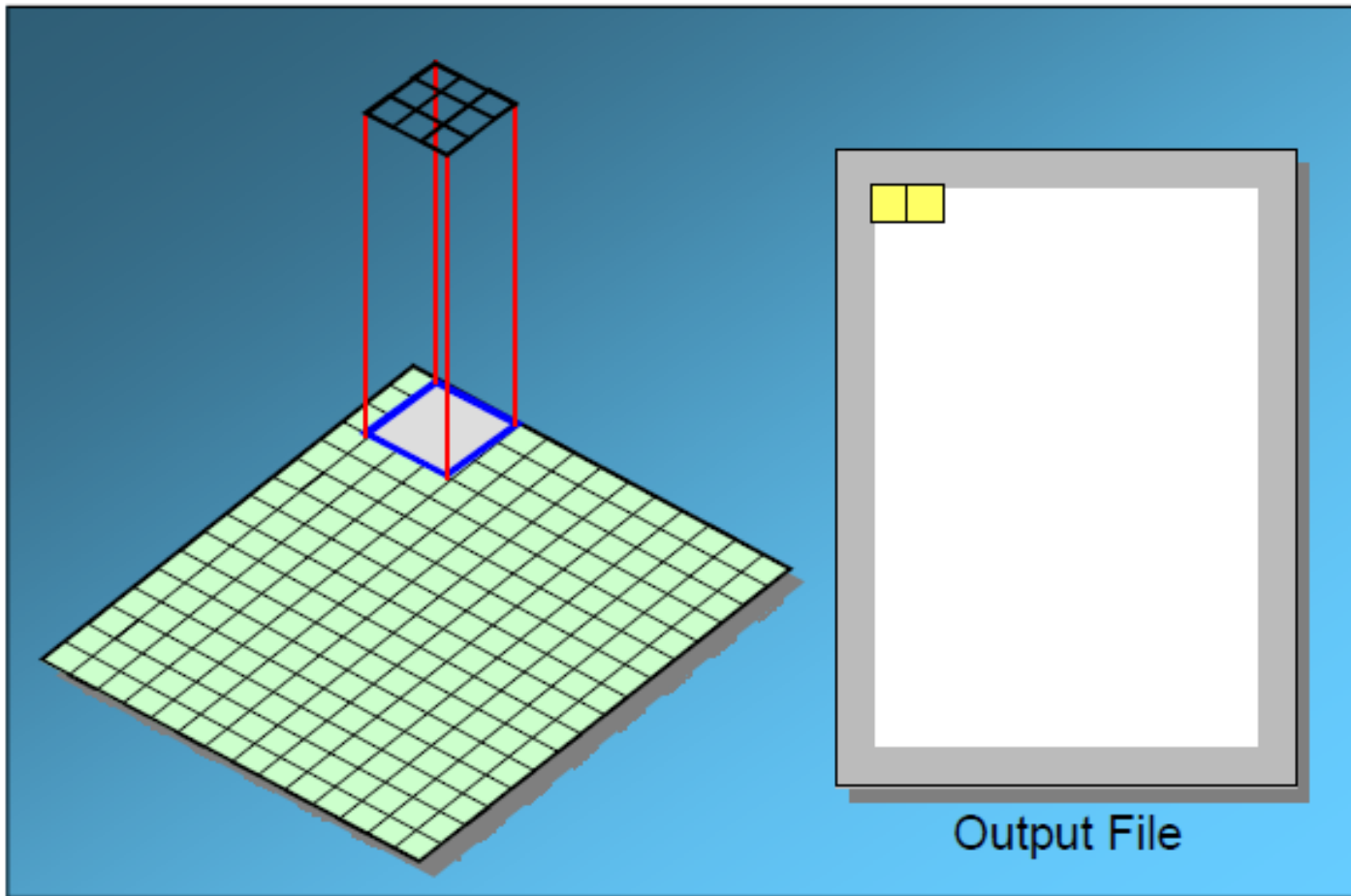

Spatial Filtering: Basics

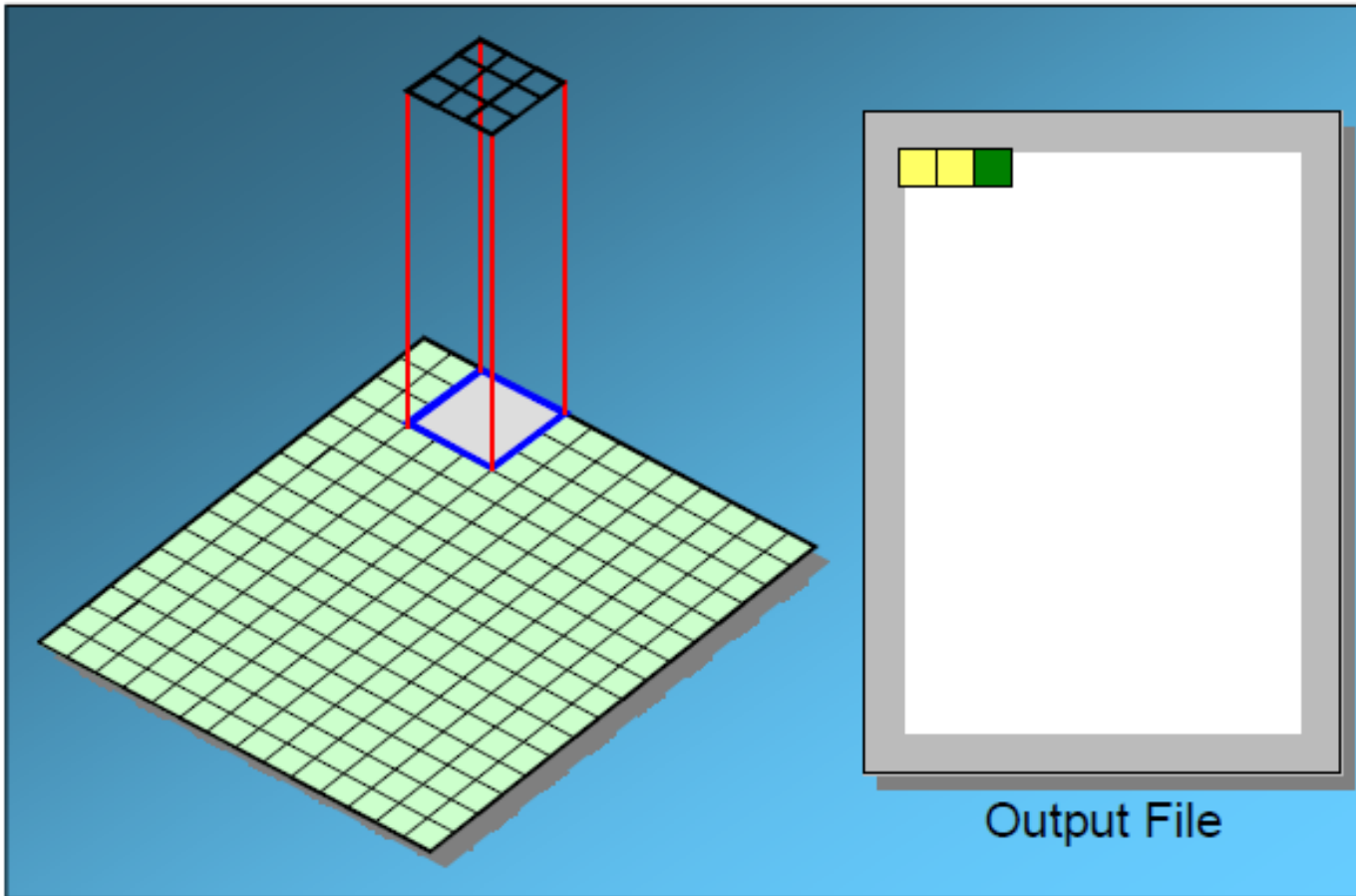

Spatial Filtering: Basics

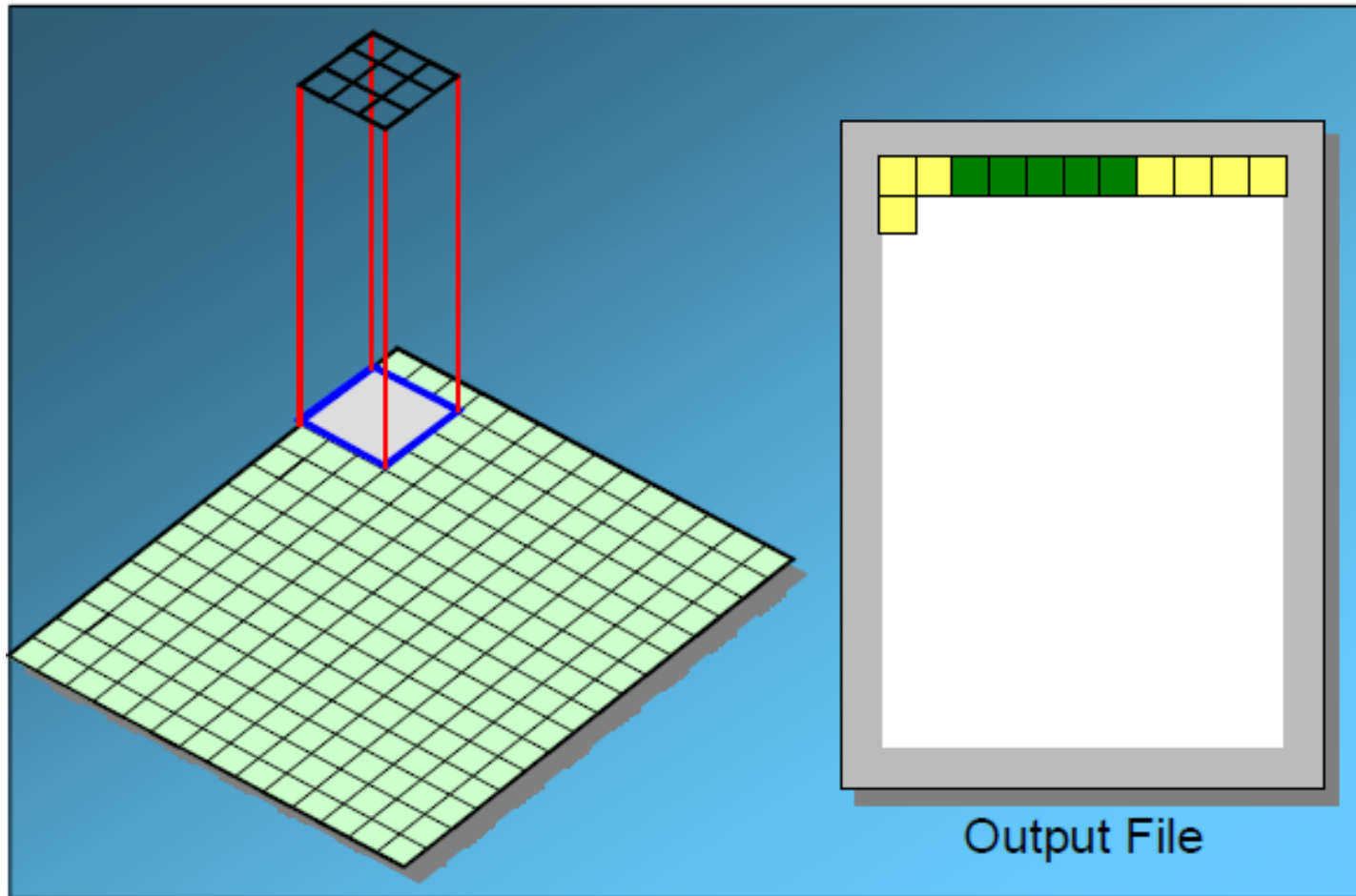

Spatial Filtering: Basics

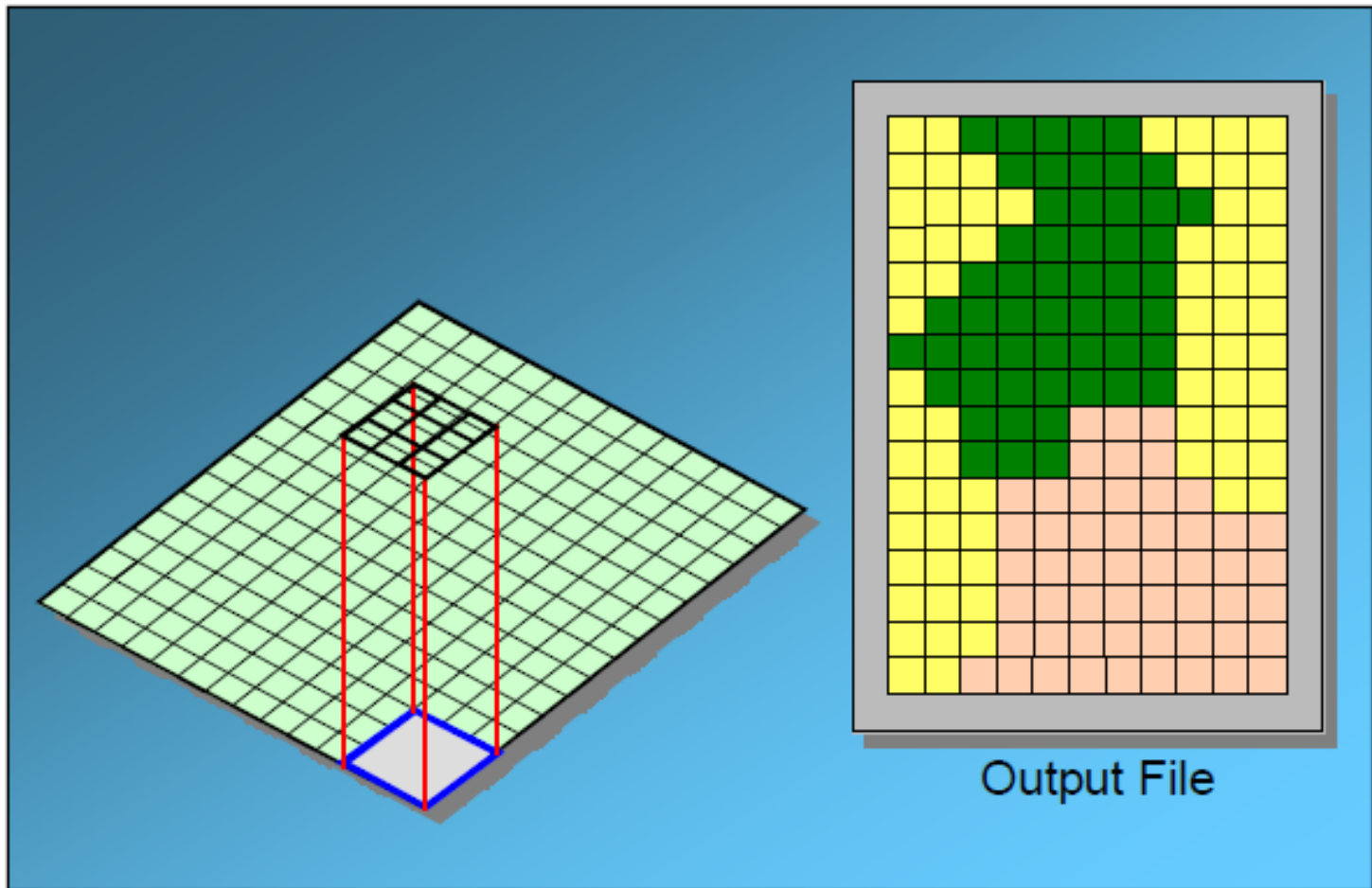

Spatial Filtering: Basics

Mask operation near the image border: Problem arises when part of the mask is located outside the image plane

Discard the problem pixels (e.g. 512x512 input 510x510 output if mask size is 3x3)

Zero padding: Expand the input image by padding zeros (512x512 original image, 514x514 padded image, 512x512 output)

Zero padding is not recommended as it creates artificial lines or edges on the border

Pixel replication: We normally use the gray levels of border pixels to fill up the expanded region (for 3x3 mask). For larger masks a border region equal to half of the mask size is mirrored on the expanded region.

Spatial Filtering: Basics

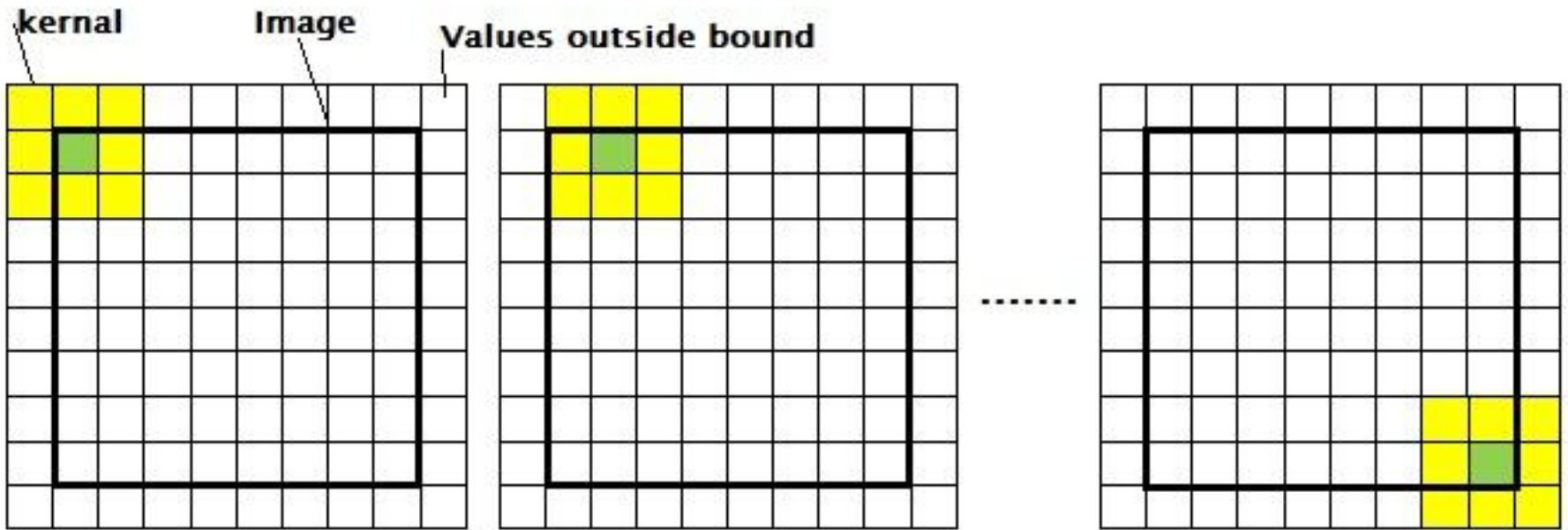

Mask operation near the border: Pixel replication

102	102	130	143	123	115
102	102	130	143	123	115
93	93			
98	98	...					
82	82	...					
65	65						
...	...						
...	...						

Expanded area

Original image size
(shaded area)

Smoothing Spatial Filters

Simply average all of the pixels in a neighbourhood around a central value

$1/9$	$1/9$	$1/9$
$1/9$	$1/9$	$1/9$
$1/9$	$1/9$	$1/9$

**Simple
averaging
filter**

Smoothing Spatial Filters

- ◆ For blurring/noise reduction
- ◆ Blurring is usually used in **preprocessing steps**, e.g., to remove small details from an image prior to object extraction, or to bridge small gaps in lines or curves
- ◆ **Equivalent to Low-pass spatial filtering** in frequency domain because smaller (high frequency) details are removed based on neighborhood averaging (averaging filters)

Smoothing Spatial Filters

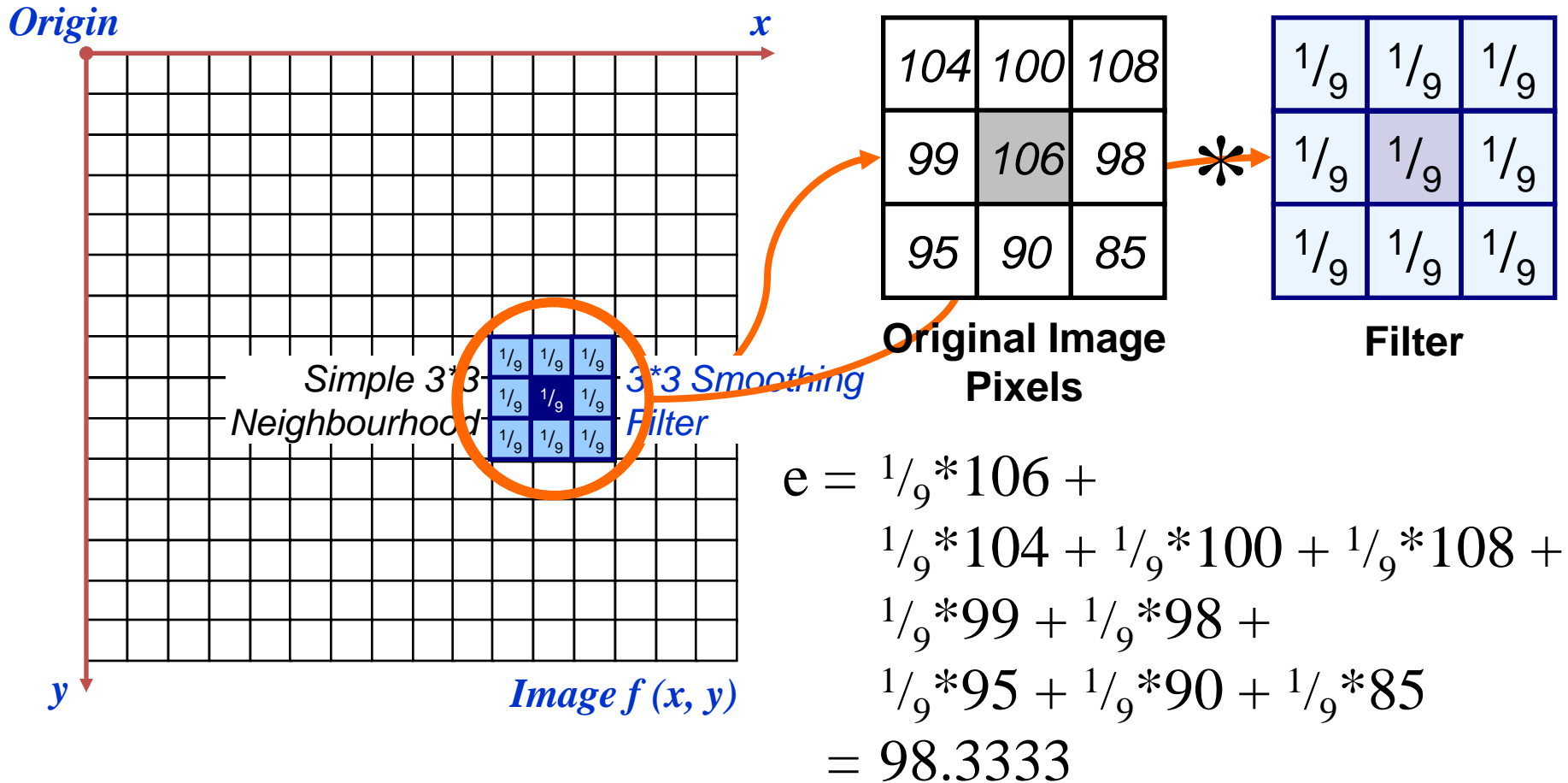

The above is repeated for every pixel in the original image to generate the smoothed image

Smoothing Filter: Example



original

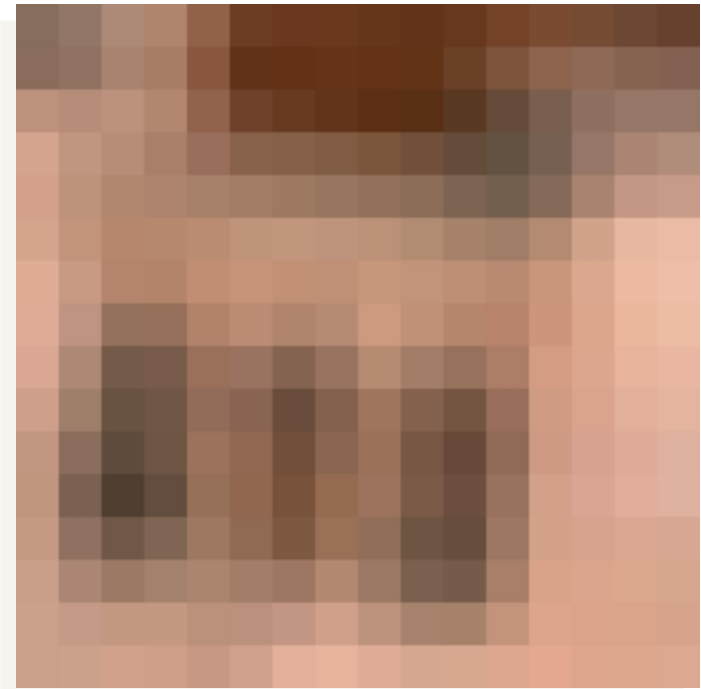

3x3 average

Smoothing Filter: Example

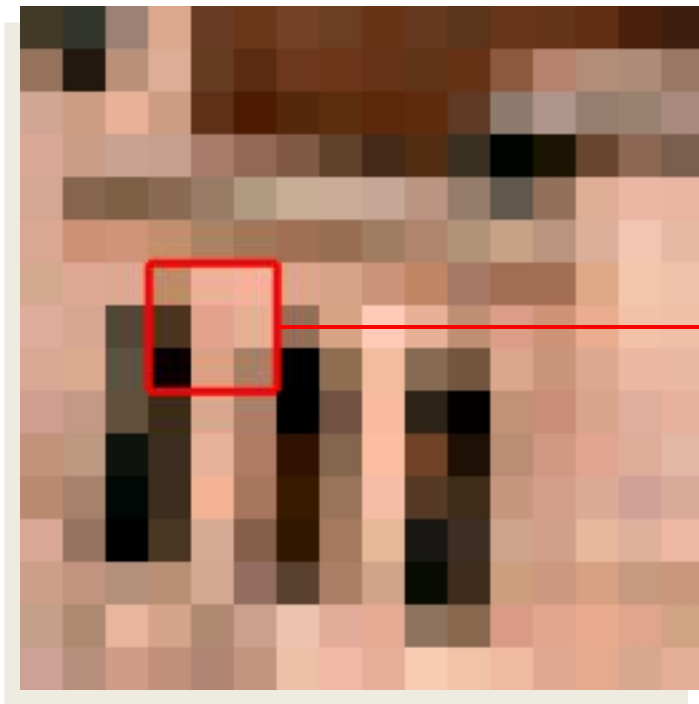

original

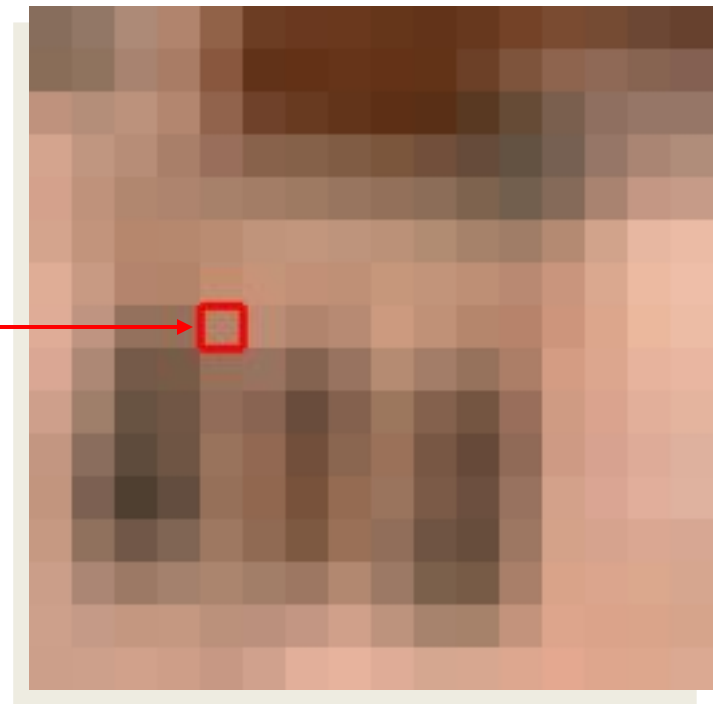

3x3 average

Smoothing Filter: Example

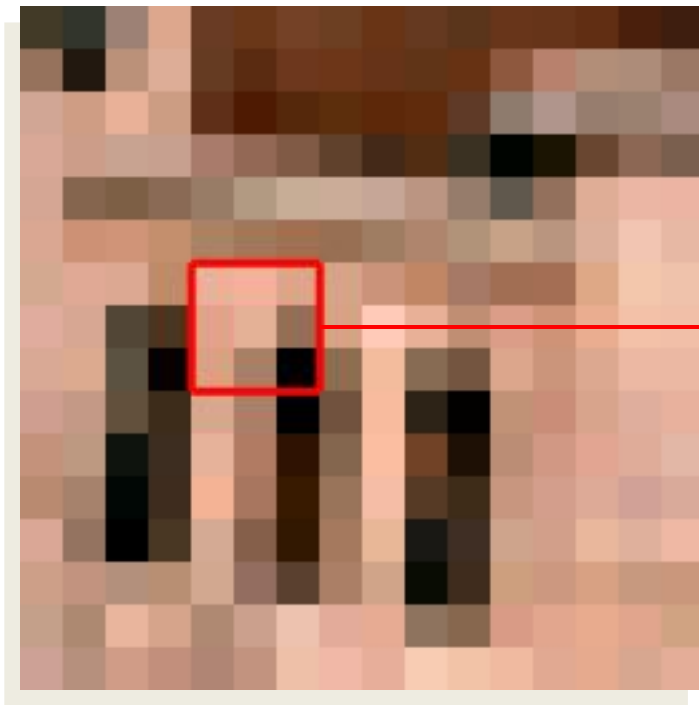

original

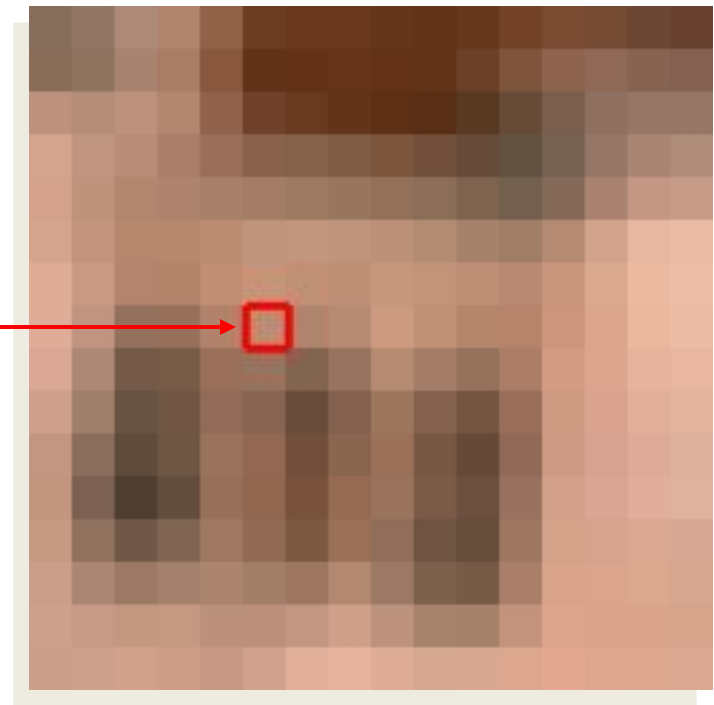

3x3 average

Smoothing Filter: Example

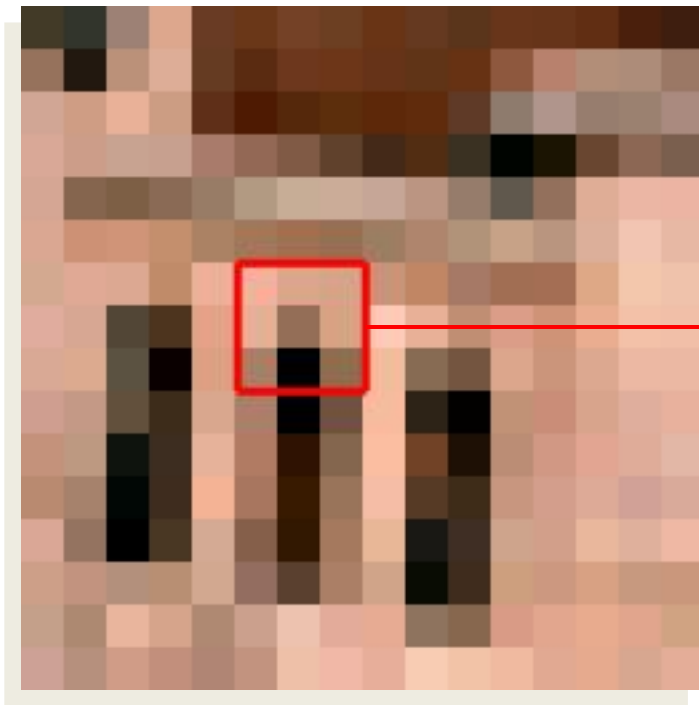

original

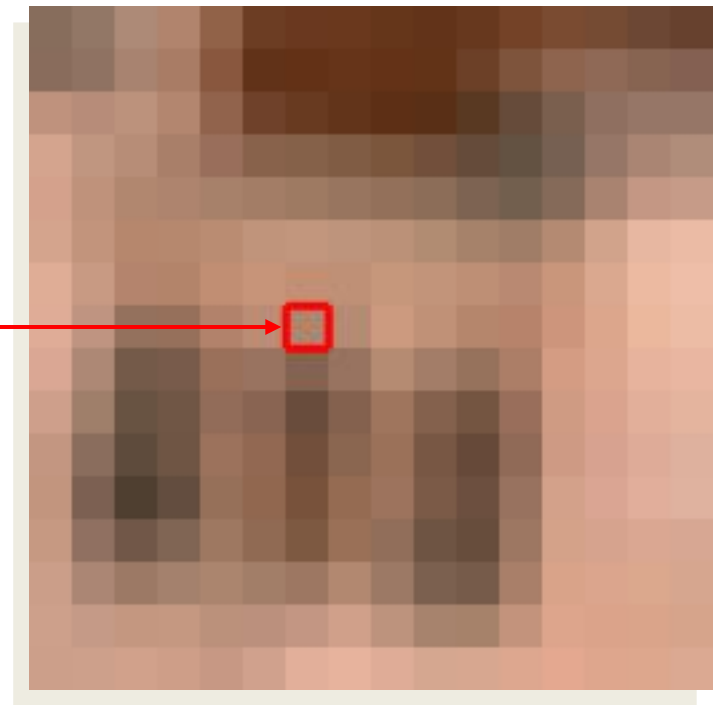

3x3 average

Original image
Size: 500x500

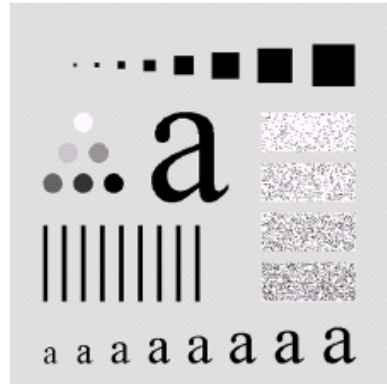

**Smooth by 3x3
box filter**

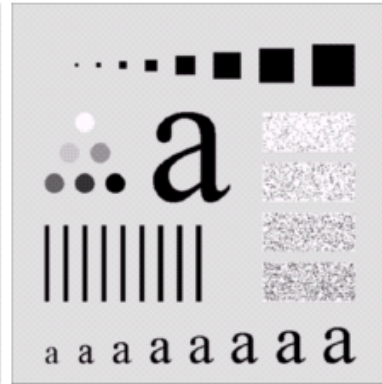

**Smooth by 5x5
box filter**



**Smooth by 9x9
box filter**

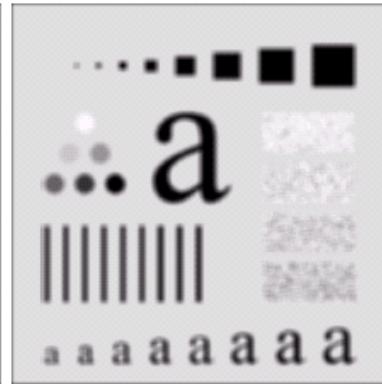

**Smooth by
15x15 box filter**

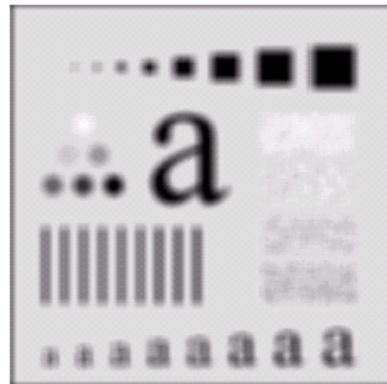

**Smooth by
35x35 box filter**



Notice how detail begins to disappear

Smoothing Spatial Filters

$\frac{1}{9} \times$

1	1	1
1	1	1
1	1	1

$\frac{1}{16} \times$

1	2	1
2	4	2
1	2	1

Consider the output pixel is positioned at the center

Box Filter all coefficients are equal

Weighted Average give more (less) weight to near (away from) the output location

Order-Statistic Filtering

- ◆ Output is based on order of gray levels in the masked area
- ◆ Some simple neighbourhood operations include:
 - **Min:** Set the pixel value to the minimum in the neighbourhood
 - **Max:** Set the pixel value to the maximum in the neighbourhood
 - **Median:** The median value of a set of numbers is the midpoint value in that set

Median Filter



- For an image, mask symmetric: 3x3, 5x5, etc.

Sorted: 0,0,1,1,1,2,2,2,4

Input

1	2	0	1	3	
2	2	4	2	2	
1	0	1	0	1	
1	2	1	0	2	
2	5	3	1	2	

Output

	1				

Median Filtering

10	20	20
20	15	20
20	25	100

Sort the values
Determine the median

Median = ? **20**

- ◆ **Particularly effective when**
 - The noise pattern consists of strong impulse noise (salt-and-pepper)

Salt and Pepper Noise



Median Filtering

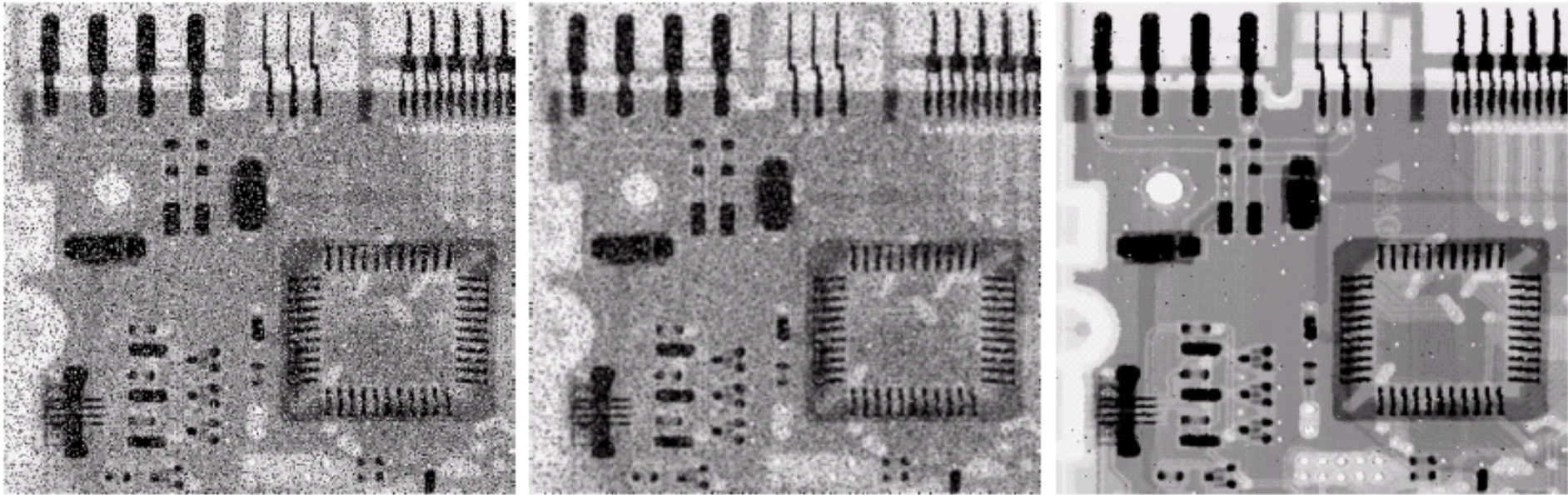

a b c

FIGURE 3.37 (a) X-ray image of circuit board corrupted by salt-and-pepper noise. (b) Noise reduction with a 3×3 averaging mask. (c) Noise reduction with a 3×3 median filter. (Original image courtesy of Mr. Joseph E. Pascente, Lixi, Inc.)

Median Filtering

a	b
c	d

FIGURE 5.10

- (a) Image corrupted by salt-and-pepper noise with probabilities $P_a = P_b = 0.1$.
(b) Result of one pass with a median filter of size 3×3 .
(c) Result of processing (b) with this filter.
(d) Result of processing (c) with the same filter.

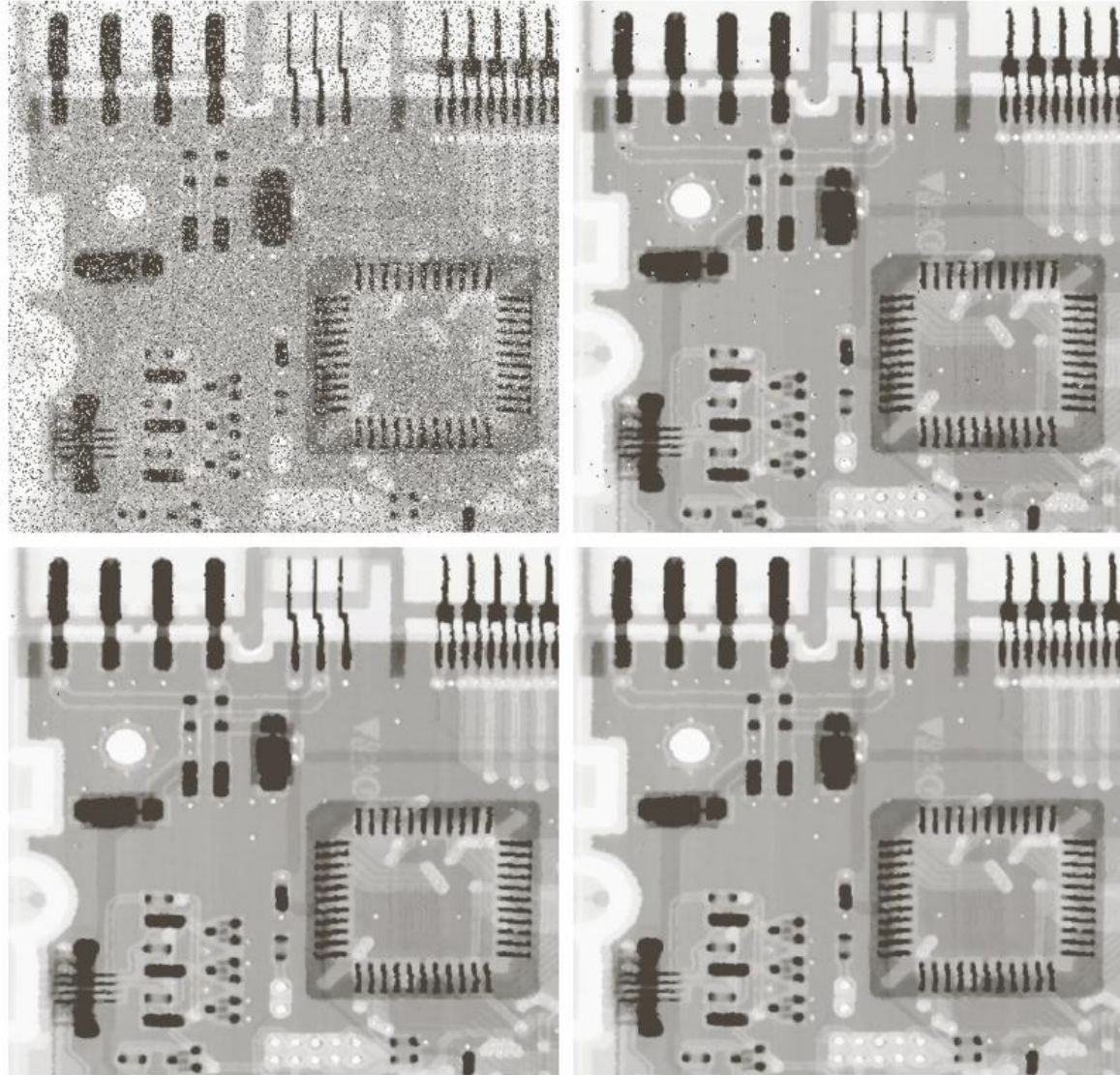

Readings from Book (3rd Edn.)

- Spatial filtering



Acknowledgements

- ◆ Digital Image Processing”, Rafael C. Gonzalez & Richard E. Woods, Addison-Wesley, 2002
- ◆ Peters, Richard Alan, II, Lectures on Image Processing, Vanderbilt University, Nashville, TN, April 2008
- ◆ Brian Mac Namee, Digital Image Processing, School of Computing, Dublin Institute of Technology
- ◆ Computer Vision for Computer Graphics, Mark Borg